



WATER GARDEN PRODUCTS CATALOG

2013

 **Atlantic™**
Discover the Difference

Table of Contents

COLORFALLS PRODUCTS

Color Changing Colorfalls	6-7
Classic Colorfalls	8
NEW! Colorfalls Stainless Steel Scuppers	9
NEW! Colorfalls Kits & Accessories	10-11

OASIS PRODUCTS

Pond Products	14-15
Pond-free Products	16-17
NEW! Fountain Products	18-19

PRO SERIES PRODUCTS

Skimmers	22-23
FilterFalls	24-25
Fastfalls	26
Eco-Blox	27
Eco-Rise & TR3WAY	28
Fountain Basins	29
NEW! Fountains	30-31
Pond Kits	32-33

TIDALWAVE PRODUCTS

Comprehensive Pump Chart	35
Pump Protector	36
Fountain Pumps	37
Mag Drive Pumps	38-39
TidalWave2 Series Pumps	40
SH-Series Pumps	41
PAF Series Pumps	42
A-Series & L-Series Pumps	43

INSTALLATION PRODUCTS

Triton Check Valve & AWGCV30	45
Installation Products	46-47



LIGHTING PRODUCTS

SOL Lighting	49
NEW! SOL Color Changing	50-51

ACCESSORIES

Rock Lids	53
Skimmer Accessories	54
FilterFalls Accessories	55

MAINTENANCE

NEW! Triton Ionizer	57
Biocuda Treatments	58-59
Biocuda Fish Food	60
NEW! Typhoon Air Pumps	61
Pond & Garden Protectors	62
Ultra Pond Nets	63

RAIN HARVESTING PRODUCTS

Clean Rain Ultra	65
Pump Vault	66
Pumps	67
Accessories	68
Kits	69

CLASSIC ATLANTIC PRODUCTS

Skimmers	70
FilterFalls	71



NEW for 2013

PAGES 30-31



Color Changing Vases

A completely new concept: overflowing vases that glow from within! These fountain pieces are equipped with remote controlled color changing lights and are available in three sizes.

Stainless Steel Scupper

These sleek, modern scuppers add a new element to our formal water feature line, and work seamlessly with Atlantic's Basin Kits.

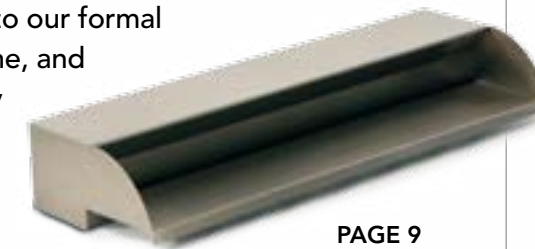

PAGE 9

ALSO NEW in 2013

Basin Kits	10
Stainless Steel Splash Rings	11
Pro Series Fountain Pieces	30
MD250 Mag Drive Pump	38
TidalWave Fountain Heads	39
AWGFT2 Fountain Light	49
Typhoon Air Pumps	61

Oasis Fountain Kits

Installing a water feature couldn't be easier than with Atlantic's all new Oasis Fountain Kits.

PAGES 18-19



Triton Ionizer

PAGE 57

Completely redesigned to mate perfectly with our Award Winning Triton Check Valve for simple installation and tool-free electrode replacement!

SOL Lighting

Available in both warm white and Color Changing, the NEW SOL Lights feature a brass body with an oil rubbed finish that adds class while reducing the heat emitted.



PAGES 49-51

Colorfalls Products

Carry the beauty of water deep into the evening with Atlantic's Colorfalls, the first lighted weir specifically designed for water features. Our newest models continue to lead the industry in appearance and functionality. Available in solid colors, color changing, and now in four different sizes, Colorfalls will add simple, elegant beauty to your outdoor space, day and night.

Colorfalls
LIGHTED FALLS

The Complete Colorfalls System:

The Atlantic Colorfalls System is what sets us apart from the rest. Not just an attractive accent, Colorfalls are the centerpiece of a well-designed outdoor living installation.

Colorfalls Systems feature:

- Basin dimensions that work with popular retaining walls and paving stones for easy installation with minimal cutting.
- Built-in plumbing recesses that enable all plumbing to be installed within the dimensions of the basin, for clean lines and no saw cuts.
- A pump chamber, separated from the rest of the basin by a Matala filter mat that diffuses water turbulence, eliminates bubbles and allows more light to travel through the falls.
- An all-new body design for the Color Changing Colorfalls that offers complete access to internal components, multiple plumbing and color options and the unmatched capacity to join any number for falls of unlimited width!

Atlantic's Colorfalls System is not the best by accident; it's the best by design.



COLORFALLS

Colorfalls Installation

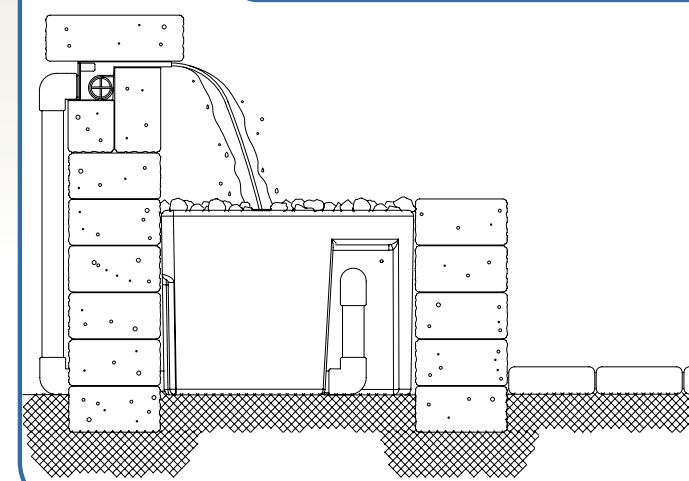

Colorfalls

COLOR CHANGING

Create brilliant effects with Atlantic's completely redesigned Color Changing Colorfalls. The new weir style creates a thicker, fuller sheer that adds body and extra color to your falls with less wind deflection, and the modular design allows custom spillways of any width! The light bar offers 48 vibrant color options and patterns via remote control, and an optional Master Controller will synchronize the displays of up to five units, separate or connected. Stand out from the crowd!



Each Color Changing Colorfalls includes a Single Control Module & Remote Control

Input Voltage: 12 Volt AC
Output Voltage: 12 Volt DC / 4-wire

NOT COMPATIBLE WITH SOL COLOR CHANGING LIGHTING

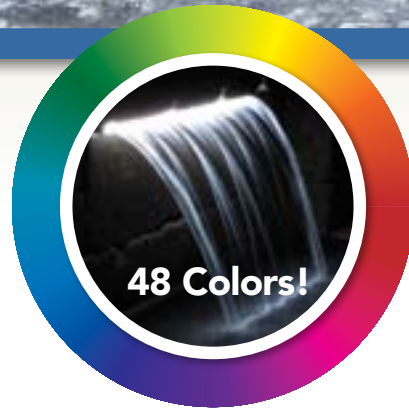

ColorChanging FEATURES:

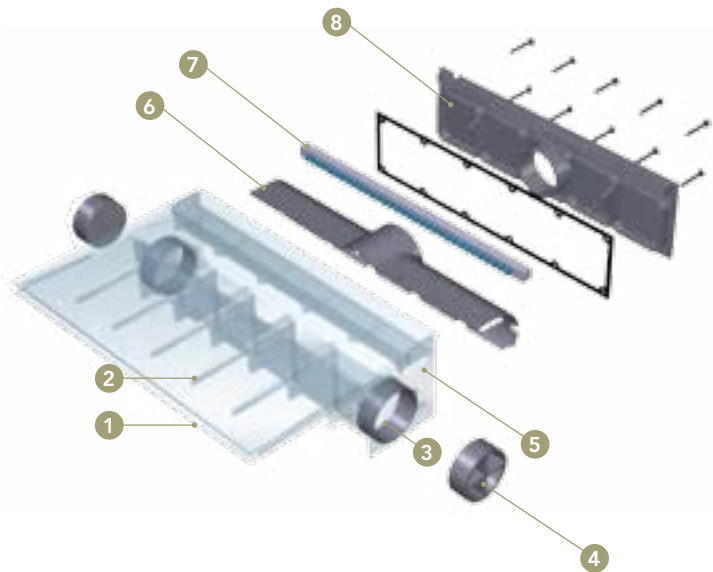

1. Larger weir opening produces a thicker sheer, less splash, more color and less chance of clogging
2. Redesigned supports eliminate splitting of the water sheer and increase load capacity
3. 1½" side and back plumbing options for maximum versatility
4. Includes 2 – 1½" plugs for unused plumbing inlets
5. Self-draining body for easy winterization
6. Removable baffle for easy cleaning and servicing
7. Color Changing LED light bar that is accessible from the rear of the unit
8. Removable back plate provides unparalleled access to the interior and light bar for routine maintenance

PATENT PENDING

Master Controller

Whether you want to create a single, seamless waterfall up to 15 feet wide, or to synchronize up to five individual Color Changing Colorfalls, the CCCM05 Master Controller makes syncing a snap. Simply plug the Color Changing light bars into the five-way splitter to control as many as five different Color Changing Colorfalls with a single control module and a single remote!



Model: **CCCM05**
Description: Master Control Module for Color Changing Colorfalls
Input Voltage: 120 Volt AC
Output Voltage: 12 Volt AC / 80 watts
Dimensions: 6"L x 3¼"D x 3¼"H
Includes: 80 watt transformer and 5-way splitter
Warranty: 1 year

MODELS:

Model: **CC06**
Description: 6" Color Changing Colorfalls
Flow Rate: 600 gph
Input Voltage: 12 volt DC
Watts: 3.5 variable
Inlet: 1½" Sch 40 socket
Dimensions: 6"W x 8"D x 3½"H
Application: Formal

Model: **CC12**
Description: 12" Color Changing Colorfalls
Flow Rate: 1,200 gph
Input Voltage: 12 volt DC
Watts: 7 variable
Inlet: 1½" Sch 40 socket
Dimensions: 12"W x 8"D x 3½"H
Application: Formal

Model: **CC24**
Description: 24" Color Changing Colorfalls
Flow Rate: 2,400 gph
Input Voltage: 12 volt DC
Watts: 14 variable
Inlet: 1½" Sch 40 socket
Dimensions: 24"W x 8"D x 3½"H
Application: Formal

Model: **CC36**
Description: 36" Color Changing Colorfalls
Flow Rate: 3,600 gph
Input Voltage: 12 volt DC
Watts: 20 variable
Inlet: 1½" Sch 40 socket
Dimensions: 36"W x 8"D x 3½"H
Application: Formal

Color Changing Colorfalls Features:

- 5" lip extension
- 12 volt single control module with weather resistant outdoor enclosure & remote control
- 20' power cord
- 1-year warranty



Colorfalls

LIGHTED FALLS

Atlantic's Colorfalls are a perfect fit for formal retaining walls and pond-free applications. Colorfalls add a breathtaking new dimension to water features – with shimmering brilliance in red, white or blue. Enjoy the beauty of your water feature day or night!



NEW!

Stainless Steel Scuppers

Atlantic's NEW Stainless Steel Scuppers bring a gleaming new dimension to our spillway line. Constructed of durable 304 stainless steel and available in the same sizes as our popular Colorfalls, these sleek modern Scuppers put a sharp, fresh shine on your formal water feature project.

MODELS :

Model: CF12B Ice Blue
CF12R Fire Red
CF12W Crystal White
CF12SW SOL White

Description: 12" Colorfalls
Flow Rate: 1,000 gph
Watts: 3
Inlet: 1¼" FIPT
Dimensions: 12"W x 8"D x 3½"H
Application: Formal

Model: CF24B Ice Blue
CF24R Fire Red
CF24W Crystal White
CF24SW SOL White

Description: 24" Colorfalls
Flow Rate: 2,000 gph
Watts: 6
Inlet: 1¼" FIPT
Dimensions: 24"W x 8"D x 3½"H
Application: Formal

Model: CF36B Ice Blue
CF36R Fire Red
CF36W Crystal White
CF36SW SOL White

Description: 36" Colorfalls
Flow Rate: 3,000 gph
Watts: 9
Inlet: 1¼" FIPT
Dimensions: 36"W x 8"D x 3½"H
Application: Formal

Colorfalls Features:

- 5" lip extension
- 12 volt outdoor transformer
- 30' power cord
- 1-year warranty



Colorfalls come in four vibrant colors:

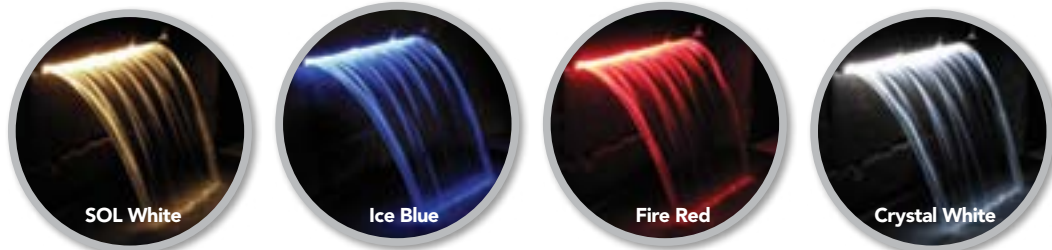

MODELS :

Model: SS12
Description: 12" Stainless Steel Scupper
Flow Rate: 1,200 gph
Inlet: 1½" FIPT
Dimensions: 12"W x 8½"D x 4"H
Application: Formal

Model: SS24
Description: 24" Stainless Steel Scupper
Flow Rate: 2,400 gph
Inlet: 1½" FIPT
Dimensions: 24"W x 8½"D x 4"H
Application: Formal

Model: SS36
Description: 36" Stainless Steel Scupper
Flow Rate: 3,600 gph
Inlet: 1½" FIPT
Dimensions: 36"W x 8½"D x 4"H
Application: Formal

Scupper Features:

- 5" lip extension
- Fully welded enclosure
- 304 Stainless steel
- 1-year warranty



NEW!

Basin Kits

Atlantic Basin Kits are designed to fit perfectly with all of our formal spillways - the Color Changing Colorfalls, the Classic Colorfalls and our new Stainless Steel Scuppers. Whether you're adding the shimmering nighttime enchantment of a Colorfalls or an elegant touch of class with a Stainless Steel Scupper, our Basin Kits provide everything you need to complete the installation, from the reservoir to the plumbing to the pump, with all the fittings, double filtration, splash mat, even an Automatic Fill Valve!



Basins & Accessories

Want an elegant new way to control splash? Our new Stainless Steel Splash Rings tame errant droplets and complement all of our formal spillways, with 304 Stainless mesh and sides so all you see is polished steel. Add a new SOL Light Ring for a dramatic nighttime effect!



MODELS :



12" Basin Kit

Model: CFBASINKIT12
Description: Complete Basin Kit
For Use With: All 12" spillways
Dimension: 20"W x 20"D x 16"H
Application: Formal
Includes: CFBASIN12 and TW1200 pump



24" Basin Kit

Model: CFBASINKIT24
Description: Complete Basin Kit
For Use With: All 24" spillways
Dimension: 44"W x 22"D x 16"H
Application: Formal
Includes: CFBASIN24 and TW2400 pump



36" Basin Kits

Model: CFBASINKIT36
Description: Complete Basin Kit
For Use With: All 36" spillways
Dimension: 56"W x 24"D x 16"H
Application: Formal
Includes: CFBASIN36 and TW3700 pump

MODELS : **NEW!**



Model: CFSR12
Description: Stainless Steel Splash Ring
For Use With: CFBASIN12
Dimensions: 16"W x 8"D x 1½"H
Application: Formal



Model: CFSR24
Description: Stainless Steel Splash Ring
For Use With: CFBASIN24
Dimensions: 28"W x 8"D x 1½"H
Application: Formal



Model: CFSR36
Description: Stainless Steel Splash Ring
For Use With: CFBASIN36
Dimensions: 40"W x 8"D x 1½"H
Application: Formal

MODELS :



Model: CFBASIN12
Dimension: 20"W x 20"D x 16"H
Capacity: 18 Gallons
Filtering: Matala Filter Mat
Application: Formal



Model: CFBASIN24
Dimensions: 44"W x 22"D x 16"H
Capacity: 33 Gallons
Filtering: Matala Filter Mat
Application: Formal



Model: CFBASIN36
Dimension: 56"W x 24"D x 16"H
Capacity: 42 Gallons
Filtering: Matala Filter Mat
Application: Formal



Basin Kit Installation

Basin Kits Include:

- Colorfalls Basin & TW2 Pump
- 1½" x 10' Flexible PVC Pipe
- Splash Mat
- AF1000 Auto Fill
- Complete Installation Kit including pump discharge, flow valve, spray glue and thread sealant

Colorfalls Basin Features:

- Pre-filtered pump chamber
- One-piece construction
- Built-in plumbing channels
- Can be installed above or below grade
- For use with Colorfalls and Stainless Steel Scuppers

8oz. Biocuda Colorfalls & Fountain Treatment

Model: CFFT800

- Clears water fast!
- For use with Colorfalls and all Pond-free fountains



Oasis Products

Just the right fit. Atlantic's Oasis brand offers the perfect balance of features and performance for professional installers or the advanced do-it-yourselfer. The Oasis Series has the same exceptional strength and durability as our professional line in a compact user-friendly format for smaller installations.



The Complete Oasis System:

Atlantic's Oasis System offers the same quality as contractor grade equipment, simplified and downsized for smaller projects that need to meet great expectations without downsizing standards. We developed the Oasis Series specifically for contractors and DIY homeowners who want the best, fully-featured products in sturdy, compact footprints.

Oasis Features:

- Easier to install and maintain: designed to cater to the novice pond builder, while still offering the same quality as our Pro Series. The only tools needed to install Oasis Series Products are a screwdriver and a hand saw.
- Durable, sturdy components built to perform better and stand the test of time: a deeper Skimmer to house oversized filter components; a reinforced FilterFalls with solid lip and molded inserts; a ribbed Pump Vault that cannot crush or warp and a buttressed FastFalls that can support a ton without leaking.
- Easy to sell and support: the streamlined series is designed to cover a wide array of installations with no doubt about which products to choose or how to match components.

With this easy-to-understand system, you can truly relax; we've got your backyard Oasis.



OASIS



SP1600 FastFalls and PV1700 Pump Vault shown



PS3900 Skimmer and BF1600 FilterFalls shown

Oasis Skimmer & FilterFalls

Atlantic's Oasis Series is the first line of retail water gardening products built to contractor standards. These exceptionally well-designed units feature heavy walled high density polyethylene construction, attractive rolled rims for strength and rigidity and stainless steel hardware - contractor grade equipment sized for the smaller water garden.

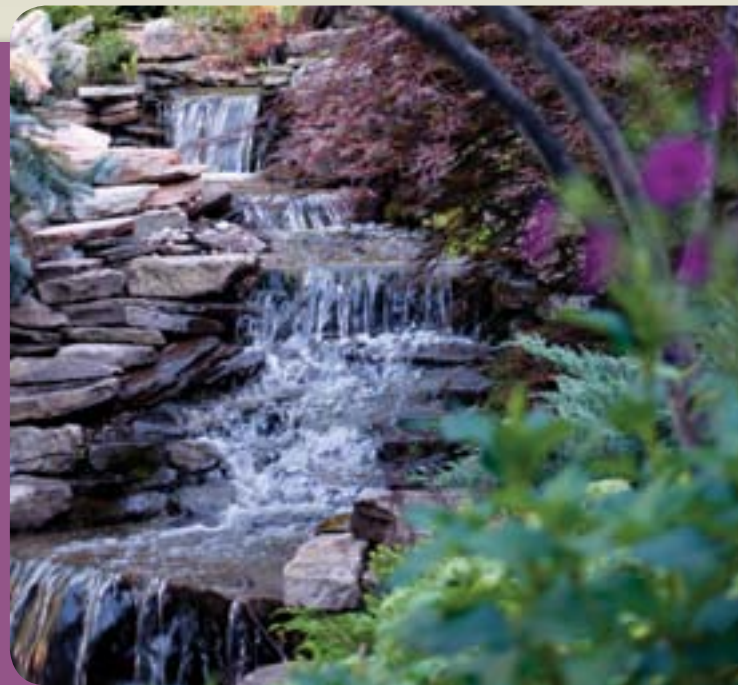

Oasis Pond Kit



Kit No.	Pond Size	Liner Size	Pump	Hose Size
PKOASIS	11' x 11'	15' x 15'	TW2400	1½" x 25'

KIT INCLUDES:

- PS3900 Skimmer
- BF1600 FilterFall
- TW2400 TidalWave2 Pump
- Triton Check Valve
- 1½" x 25' Flexible PVC Pipe
- 15' x 15' liner
- Heavy-duty Underlayment
- Complete Installation Kit Including Fittings, Thread Sealant and PVC spray glue

MODEL:



Model: **PS3900**
 Weir Width: 6"
 Dimensions: 17¾"W x 19½"D x 19½"H
 Pump Flow Range: 1,000 - 3,900 gph
 Sq. Ft. Rating: 200
 Filtering: Net, Matala mat
 Match to FilterFalls: BF1600

Oasis Skimmer PS3900 Features:

1. Sturdy removable lid supports natural rock camouflage and foot traffic
2. Support bar for added strength
3. Stainless steel-framed trap net and Matala filter mat provide mechanical filtration
4. High density polyethylene enclosure
5. Rolled upper rim provides clean lines and incredible strength
6. Pump discharge step fittings for 1½" & 2" pipe provided on both sides of the skimmer
7. Super Flow weir door for maximum surface cleaning
8. Labeled drill points for the installation of Auto Fill and overflow (not shown)



MODEL:



Model: **BF1600**
 Waterfall Width: 16" spillway
 Dimensions: 21½"W x 19½"D x 17¾"H
 Pump Flow Range: 1,000 - 3,900 gph
 Bulkhead: 1½"
 Match to Skimmer: PS3900

Oasis FilterFalls BF1600 Features:

1. Sturdy top grate and support bar allow natural rock camouflage
2. Dual Bio-Tech filter mats and media bag for biological filtration
3. Sturdy bottom grate supports filter media
4. Rolled upper rim provides clean lines and incredible strength
5. One-piece liner attachment flange
6. Heavy-duty 1½" FIPT bulkhead



See how it all works together in a complete Oasis Ecosystem on page 13

Recommended Installation Product



Triton Check Valve

Recommended Accessories Product



RL30 Rock Lid

Recommended Maintenance Product



Biocuda Pond Treatments

Oasis Pond-free

Oasis Pond-free products bring the quality and strength you've come to expect from Atlantic to the retail market, with more compact, easier to install products that are built to withstand the same abuse as our Pro Series. Count on Atlantic's Oasis Series to deliver the performance you need for all your smaller pond-free features.



Oasis Pond-free Kit



Kit No.	Liner Size	Eco-Blox	Basin Size	Streambed
PKOASISPL	10' x 15'	2	48" x 30" x 18"	16" - 24"W x 6'L

KIT INCLUDES:

- SP1600 FastFall
- PV1700 Pump Vault
- TW2400 TidalWave2 Pump
- Triton Check Valve
- 1½" x 25' Flexible PVC Pipe
- 2 Eco-Blox
- 10' x 15' liner
- Heavy-duty Underlayment
- Complete Installation Kit Including Fittings, Thread Sealant and PVC Spray Glue

MODEL:



Model: SP1600
 Waterfall Width: 16"
 Dimensions: 16½"W x 9½"D x 7¼"H
 Max Pump Flow: 3,000 gph
 Bulkhead: 1½" FIPT
 Application: Pond-free



Oasis FastFalls SP1600 Features:

1. Internal baffles diffuse the water for an even flow across the spillway
2. Raised front radius retains natural camouflage
3. One-piece design eliminates any chance of leaks due to 'overpumping'
4. Pre-installed 1½" Spinweld® fitting simplifies plumbing connection
5. One-piece liner flange and molded inserts ensure a secure liner attachment

back

MODEL:



Model: PV1700
 Dimensions: 17"W x 12"D x 22½"H
 Max Pump Flow: 3,900 gph
 Opening: 10"
 Application: Pond-free



Oasis Pump Vault PV1700 Features:

1. Inset lid keeps gravel from falling into the vault
2. Pump discharge step fittings for 1½" & 2" pipe provided on both sides of the vault
3. Flat front panel installs tight against Eco-Blox for a compact basin
4. Recessed pockets accept Triton 3-Way Diverter for use with the Eco-Rise (see pg. 28)
5. Flat panel for 1½" pipe for use with the Eco-Rise

back



Have Questions? Atlantic Water Gardens University has answers!

Atlantic Water Gardens University is your one source for all the information you'll need to build beautiful water features. Come visit at www.atlanticwatergardens.com, we're down in the "Tools" section.



Recommended Installation Product



Auto Fill Kit

Recommended Lighting Product



3 Pack LED Lights

Recommended Maintenance Product



Biocuda Water Treatment

NEW!

Oasis Fountain

Installing a complete water feature couldn't be easier than with Atlantic's all new Oasis Fountain Kits. Whether you prefer the rugged, natural look of a Basalt Column or a beautifully finished Pebble Pot, these Kits give you everything you need for a quick and easy installation so you can sit back and relax, sit back and enjoy the soothing sounds of water. Each kit includes an FB2400 Fountain Basin, an FP200 Fountain Pump, tubing and the decorative piece of your choice.



NEW!

Oasis Fountain

The Oasis Lighted Vase Fountain Kit is another innovation from Atlantic! The unique tapered shape of the vase adds an interesting silhouette to the garden, but the night reveals the real surprise – softly glowing, color changing light from within! You choose the color and the pattern by remote control, and the Lighted Vase illuminates from the inside to add dancing ribbons of light to the water gently flowing down its sides. Each kit includes an FB2400 Fountain Basin, an FP200 Fountain Pump, an 18" Vase with Color Changing Light and Remote Control.

MODELS :

Model: FKBC16
Description: Basalt Column Fountain Kit
Includes: FB2400 Basin, FTN BC16 Basalt Column, FP200 pump and fittings



Add an AWGFT2 Fountain Light to combine a splash of warming light with the sound of water!

Model: FKPP20
Description: Pebble Pot Fountain Kit
Includes: FB2400 Basin, FTN PP20 Pebble Pot, FP200 pump and fittings



Model: FKCCV18
Description: Color Changing Vase Fountain Kit
Includes: FB2400 Basin, FTN CCV18 Color Changing Vase, FP200 pump and fittings



Oasis Fountain Basin

The new Oasis Series Fountain Basin offers the strength and features that set it apart from the rest. Recessed plumbing channels, molded support cone and heavy wall thickness normally found in contractor grade equipment make this basin the best choice for retail applications.

Model: FB2400
Dimensions: 24"L x 24"W x 10"H
Max Pump Flow: 750 gph
Plumbing Size: Up to 1/2"
Capacity: 20 Gallons
Application: Fountain
Supports Up To: 200 lbs.



Pro Series Products

Atlantic's Pro Series stands apart. Heavy walled construction resists warping and crushing, stainless steel hardware eliminates corrosion, and oversized doors, weirs and fittings optimize pump performance. The Big Bahama line features innovative, practical designs to minimize maintenance and callbacks and maximize pump life and time between cleanings.



The Complete Pro Series System:

Where other products warp, crack or leak, Atlantic's Big Bahama Pro Series keeps going. Built with heavy-duty materials designed to last, our Skimmers and FilterFalls are unsurpassed in the water gardening industry when it comes to durability and functionality. Massively strong FastFalls and Fountain Basins, Pump Vaults, Eco-Blox and the Eco-Rise round out the Pond-free product line that sets the industry standard. The line includes:

- Skimmers designed for maximum filtration that also prevent run-dry conditions that can destroy a pump.
- FastFalls that have been imitated but never matched, our Pond-free spillways are the sturdiest and easiest to install on the market.
- FilterFalls with heavy-duty top grates and support bars that allow natural rock camouflage.



PRO SERIES

- Easy liner attachments that prevent leaks in our Skimmers, FilterFalls and FastFalls.
- Multiple fountain options using our Fountain Basins, Pump Vaults, Eco-Blox and Eco-Rise. Atlantic can help you achieve any fountain installation that you can imagine.

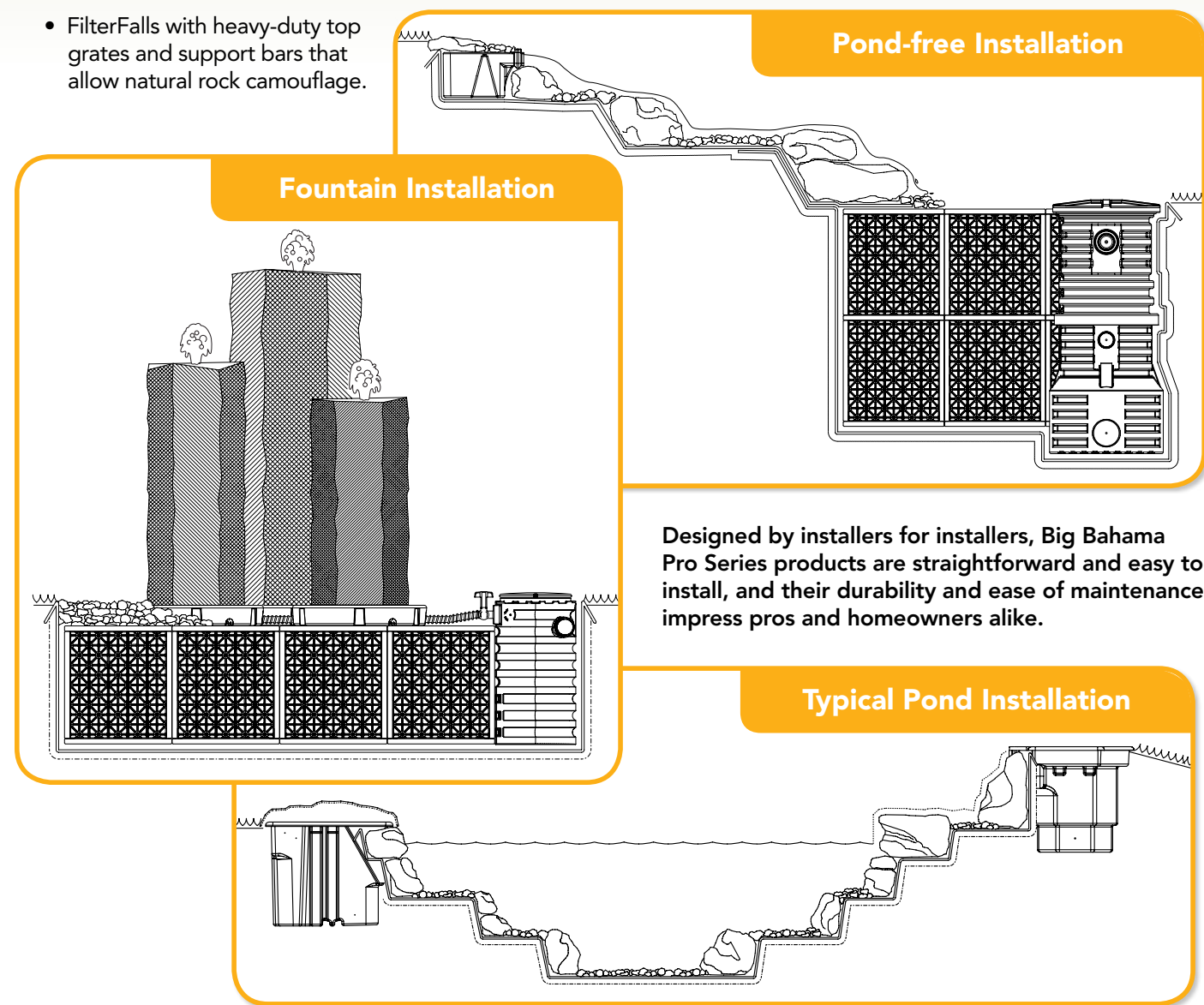

Designed by installers for installers, Big Bahama Pro Series products are straightforward and easy to install, and their durability and ease of maintenance impress pros and homeowners alike.

Pro Series Skimmers

Pro Series Skimmers set the standard for pond prefiltration, with heavy-duty construction and stainless steel components that stand up to years of service. Super Flow weir doors, framed debris nets and full-flow brush panels reduce maintenance and prolong pump life. A complete line of accessories lets you customize for every application. Best of all, Atlantic stands behind its rugged enclosures with a Lifetime Warranty.



Did You Know?



Pro Series Brush Panels keep pumps running longer!

Unlike mats and pads which block flow to the pump chamber when clogged, leading to overheating and eventual pump failure, loaded brushes push apart and allow water to pass even if they've gone too long between cleanings.



PRO SERIES

PRO SERIES

MODELS :



Model: PS4600
Weir Width: 6"
Dimensions: 19½"W x 26"D x 22"H
Max Pump Flow: 4,000 gph
Sq. Ft. Rating: 400
Filtering: Net, brush panel
Match to FilterFalls: BF1900

Model: PS7000
Weir Width: 9"
Dimensions: 25"W x 30"D x 24"H
Max Pump Flow: 7,000 gph
Sq. Ft. Rating: 900
Filtering: Net, brush panel
Match to FilterFalls: BF2600

Model: PS15000
Weir Width: 14"
Dimensions: 28"W x 33"D x 31"H
Max Pump Flow: 15,000 gph
Sq. Ft. Rating: 1400
Filtering: Net, brush panel
Match to FilterFalls: BF3800

Model: PS3000
Weir Width: 6"
Dimensions: 13"W x 13"D x 25"H
Pump Flow Range: 1,000 - 3,000 gph
Filtering: Net
Application: Satellite Skimmer - Drawing and cleaning water from hard-to-reach areas of a pond, the Satellite Skimmer is used in combination with (and plumbs into) the main pond skimmer. PS3000 installs inside or outside the pond.
Use with Skimmer: PS7000 / PS15000

Sectioned PS4600 shown with optional accessories.

SKIMMER SPECS :

Model	Weir Door	Dimensions	Max Pump Flow	Sq. Ft. Rating	Match to FilterFalls
PS4600	6"	19.5"W x 26"D x 22"H	4,000 gph	400	BF1900
PS7000	9"	25"W x 30"D x 24"H	7,000 gph	900	BF2600
PS15000	14"	28"W x 33"D x 31"H	15,000 gph	1400	BF3800

Pro Series Skimmers Feature:

1. Sturdy removable top lid supports natural rock camouflage and foot traffic
2. Heavy-duty brush panel provides maximum surface area for mechanical filtration
3. Heavy-duty stainless steel framed trap net for catching large debris
4. Rolled upper rim provides clean lines and great strength
5. Super Flow weir door for maximum surface cleaning
6. Gate Keeper brush panel (sold separately) allows leaves and debris to pass while restricting fish and frogs from entering the skimmer
7. High-density polyethylene shell for the ultimate in durability



Model PS7000 shown

Recommended Installation Product



Triton Check Valve

Recommended Accessories Product



Matala Mat Kit

Recommended Maintenance Product



All NEW Triton Ionizer

Pro Series FilterFalls

Pro Series FilterFalls deliver the performance you demand and the peace of mind you deserve. In addition to massive construction and top quality components, their innovative design allows for complete customization, with three types of filter media and a bottom chamber that accepts bulkheads on all sides. Total flexibility, add-in filtration and our Lifetime Warranty equal years of trouble-free service.



Did You Know?

The FilterFalls solid waterfall lip is a sophisticated design feature that makes the filter almost leak-proof!

Unlike other upflow filters with detachable waterfall lips, where a failure in the seal between lip and filter is a guaranteed leak, our overhanging lip carries water over the edge and safely inside the liner even if there's a failure in the silicone seal.

PRO SERIES

PRO SERIES

MODELS :



Model: **BF1900**
Waterfall Width: 19"
Dimensions: 28"W x 25"D x 21½"H
Pump Flow Range: 2,500 - 4,000 gph
Bulkhead: 2"
Match to Skimmer: PS4600



Model: **BF2600**
Waterfall Width: 26"
Dimensions: 34½"W x 25"D x 23"H
Pump Flow Range: 4,000 - 6,000 gph
Bulkhead: 2"
Match to Skimmer: PS7000



Model: **BF3800**
Waterfall Width: 38"
Dimensions: 46½"W x 30"D x 23"H
Pump Flow Range: 6,000 - 8,000 gph
Bulkhead: 3"
Match to Skimmer: PS15000



Sectioned BF1900 shown with optional accessories.

FILTERFALLS SPECS :

Model	Spillway Width	Dimensions	Pump Flow Range	Bulk-head	Pond Volume	Match to Skimmer
BF1900	19"	28"W x 25"D x 21.5"H	2,500-4,000 gph	2"	2,000 gal	PS4600
BF2600	26"	34.5"W x 25"D x 23"H	4,000-6,000 gph	2"	4,000 gal	PS7000
BF3800	38"	46.5"W x 30"D x 23"H	6,000-8,000 gph	3"	8,000 gal	PS15000

Recommended Installation Product



Foam Guns (for use with 29 oz. cans of FallsFoam)

Recommended Accessories Product



Matala Filter Kit

Recommended Maintenance Product



Biocuda Pond Treatments

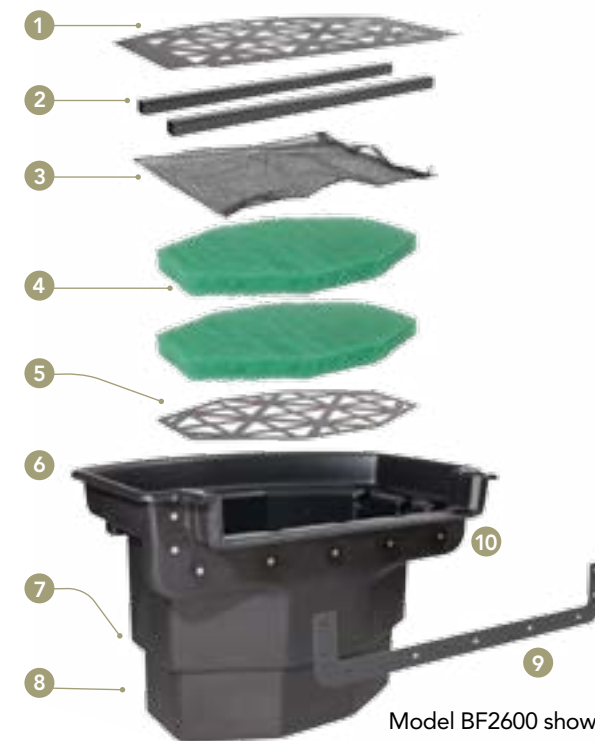

Model BF2600 shown

Pro Series FastFalls Feature:

1. Heavy-duty removable top grate supports rock camouflage
2. Support bars add stability and reinforce top grate
3. Media bag & Bio-Tech media (sold separately) provide maximum surface area for beneficial bacteria
4. Dual Bio-Tech filter mats for biological filtration
5. Sturdy bottom grate supports filter media
6. Rolled upper rim provides clean lines and incredible strength
7. 2" or 3" heavy-duty FPT bulkhead for high flow rates
8. Bottom chamber accepts bulkheads on all sides while bottom cones reduce surface area for back flushing
9. One-piece liner flange allows easy, leak-free attachment of FilterFalls to pond liner
10. Solid lip and molded inserts ensure a watertight liner attachment every time

Pro Series Pond-free



Pro FastFalls

These incredibly strong one-piece units feature an internal baffle system, support cones and a reinforced spillway. The 'inside the liner' design plus rear liner attachment simplifies installation and eliminates leakage concerns. The top can be covered with rock, gravel, soil or mulch to blend seamlessly with the surrounding landscape.

Pro Series FastFalls Feature:

1. Molded support cones give the Pro FastFalls incredible strength and help diffuse the water flow.
2. Two internal baffles slow down the water's velocity and ensure even water distribution across the spillway.
3. Raised front radius holds back any loose gravel, soil or mulch used to camouflage the top of the unit.
4. Pro FastFalls are completely sealed except for the spillway opening. This design eliminates any chance of leakage due to 'overpumping'.
5. Molded gussets support the spillway lip.
6. Pro FastFalls come with an installed 2" or 3" FIPT Spinweld® fitting.
7. One-piece liner flange and molded inserts ensure a watertight liner attachment every time.

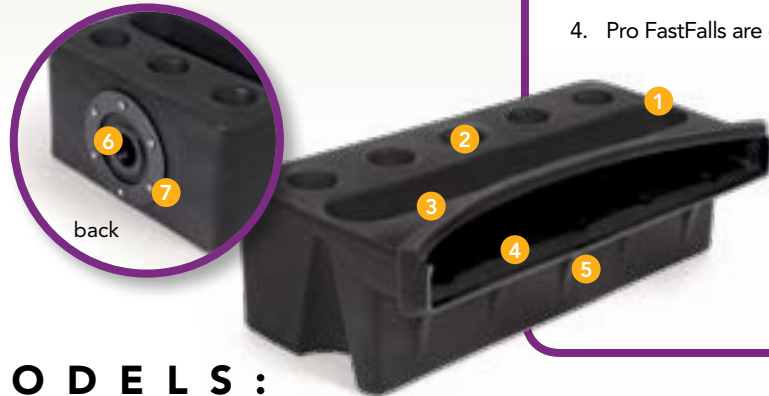

MODELS:



Model: SP1900
Dimensions: 20½"W x 17"D x 10¼"H
Waterfall Width: 19"
Max Pump Flow: 4,000 gph
Bulkhead: 2" FIPT
Application: Pond-free

Model: SP2600
Dimensions: 27½"W x 17"D x 10¼"H
Waterfall Width: 26"
Max Pump Flow: 6,000 gph
Bulkhead: 2" FIPT
Application: Pond-free

Model: SP3800
Dimensions: 39½"W x 17"D x 10¼"H
Waterfall Width: 38"
Max Pump Flow: 9,000 gph
Bulkhead: 3" FIPT
Application: Pond-free

Pump Vaults

The heavy-duty one piece design of Atlantic's Pump Vaults can accommodate large and multiple pumps and high flow rates. Features include generous openings for easy pump access, cut lines for pump discharge and pipe extensions, and flat panels for custom

plumbing. Multiple extensions can be added to increase the height for installations that require a deeper basin or greater water volumes. The depth of a pond-free basin can be increased by one Eco-Blox for each added Pump Vault extension.

Eco-Blox

Atlantic's redesigned Eco-Blox water matrix provides the same amount of water storage with improved strength and durability. The new triangular openings allow the use of smaller gravel, while H-beams that criss-cross each panel provide increased comprehensive and pointload strength for a lifetime of dependable service!



EXTRA HEAVY-DUTY CROSSBARS FOR IMPROVED POINT LOAD STRENGTH

Model: ECOBLOX
Dimensions: 27½"L x 16"W x 17½"H
Capacity: 31½ Gallons
Application: Pond-free / Fountain / Rain Harvesting

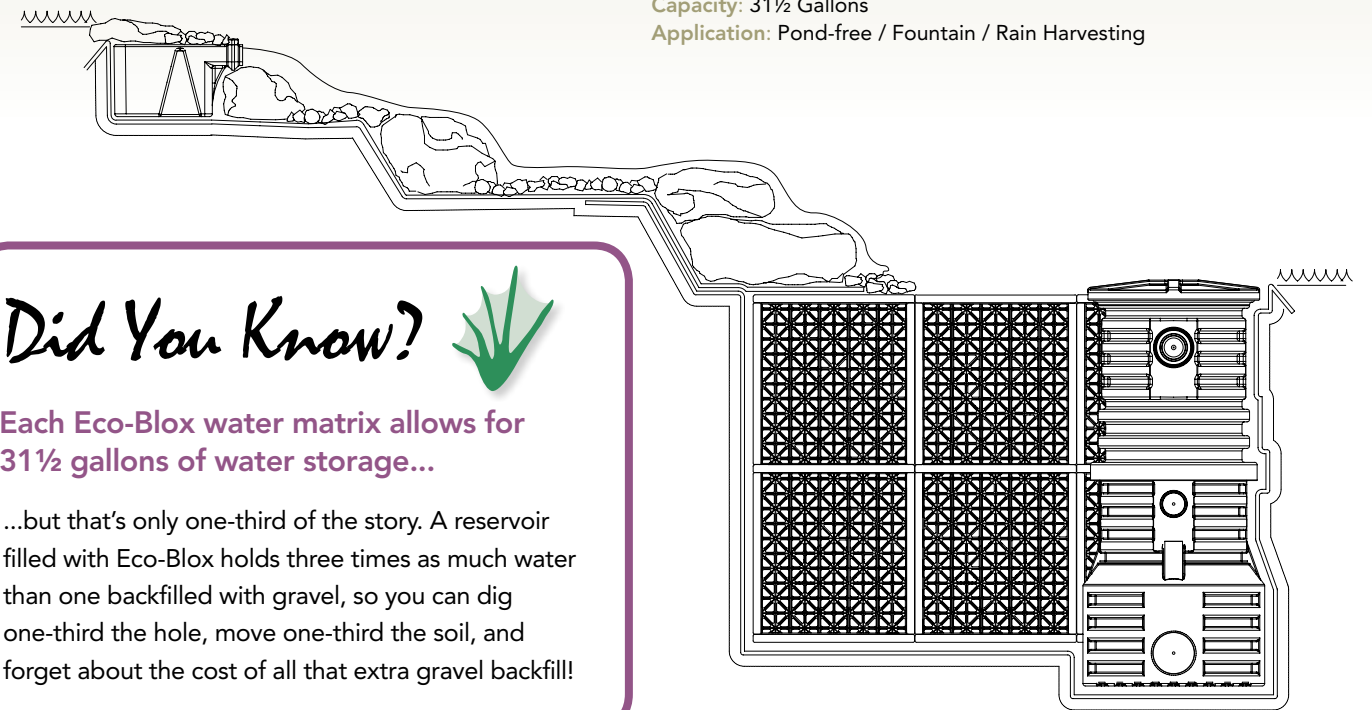

Did You Know?

Each Eco-Blox water matrix allows for 31½ gallons of water storage...

...but that's only one-third of the story. A reservoir filled with Eco-Blox holds three times as much water than one backfilled with gravel, so you can dig one-third the hole, move one-third the soil, and forget about the cost of all that extra gravel backfill!



Model: PV1800
Dimensions: 18"W x 24"H
Max Pump Flow: 10,000 gph
Opening: 14"



Model: PV18EXT
Dimensions: 16½"W x 19½"H
Extension: 17"



Model: PV2300
Dimensions: 23"W x 30"H
Max Pump Flow: 15,000 gph
Opening: 18"



Model: PV23EXT
Dimensions: 21½"W x 19½"H
Extension: 17"

Pro Series Fountain



PRO SERIES

PRO SERIES

Eco-Rise

The Eco-Rise is a totally new concept in water feature construction. The extremely strong radial structure handles the weight of heavier statuary, vases and columns while providing a broad stable base over Eco-Blox reservoirs. The versatility of the Eco-Rise used in conjunction with Eco-Blox, PV1700 Pump Vault and Triton 3-Way Diverter allows for multiple features in any configuration above odd basin shapes, while keeping plumbing and flow adjustment topside for easy access.



Model: Ecorise20
 Dimensions: 20"L x 20"W x 3"H
 Plumbing Size: 3/4" to 1 1/2"
 Max Load: 3,000 lbs.

Triton 3-Way Diverter

The Triton 3-Way Diverter is the only manifold designed exclusively for pond-free fountain installations. The 1 1/2" inlet allows unrestricted flow into the manifold, delivering the maximum possible volume to all three of the 3/4" outlets. True 'ball' style valves with removable handles enable independent flow adjustment of each outlet. The compact design makes it a perfect fit for installation in all Pump Vaults and Fountain Basins.



Model: TR3WAY
 Dimensions: 5 3/8"L x 4 1/2"W x 2 7/8"H
 Inlet: 1 1/2" FIPT
 Outlet: (3) 3/4" Insert
 Includes: (2) removable "T" handles

Fountain Basins

When they were introduced, Atlantic Fountain Basins were already the strongest and best-designed on the market, featuring deep plumbing channels on top the basins, easy access pump chambers and external flow adjustment for convenient installation and maintenance. Now they're even better, with new internal buttressing cones for greater rigidity. Count on Atlantic to keep on performing!

MODELS :



Model: FB3200
 Dimensions: 32"W x 13"H
 Max Pump Flow: 2,000 gph
 Plumbing Size: (3) 3/4" or (1) 1" hose
 Capacity: 32 Gallons
 Application: Fountain
 Supports Up To: 400 lbs.



Model: FB4600
 Dimensions: 46"W x 13"H
 Max Pump Flow: 4,000 gph
 Plumbing Size: (3) 3/4" or (1) 1 1/2" hose
 Capacity: 67 Gallons
 Application: Fountain
 Supports Up To: 1,200 lbs.

Fountain Basin Kits*



Part No. FBKIT3
 For Use With: TW1200 - 2400 & MD1000 - 2000

- Triton 3-Way Diverter
- 20' of 3/4" diameter kink-free hose
- (3) standpipe sealants
- (3) 3/4" insert x 3/4" socket fittings
- (2) 1 1/2" cord stoppers for conduit sleeves



Part No. FBKIT1
 For Use With: MD250 - 750 & FP200 - 500

- Single ball valve
- 6' of 3/4" diameter kink-free hose
- (1) standpipe sealant
- 3/4" insert x 3/4" socket fitting
- 1 1/2" cord stopper for conduit sleeve

* 3/4" PVC standpipe & pump not included

How It Works:

Typical Pond Free Installation

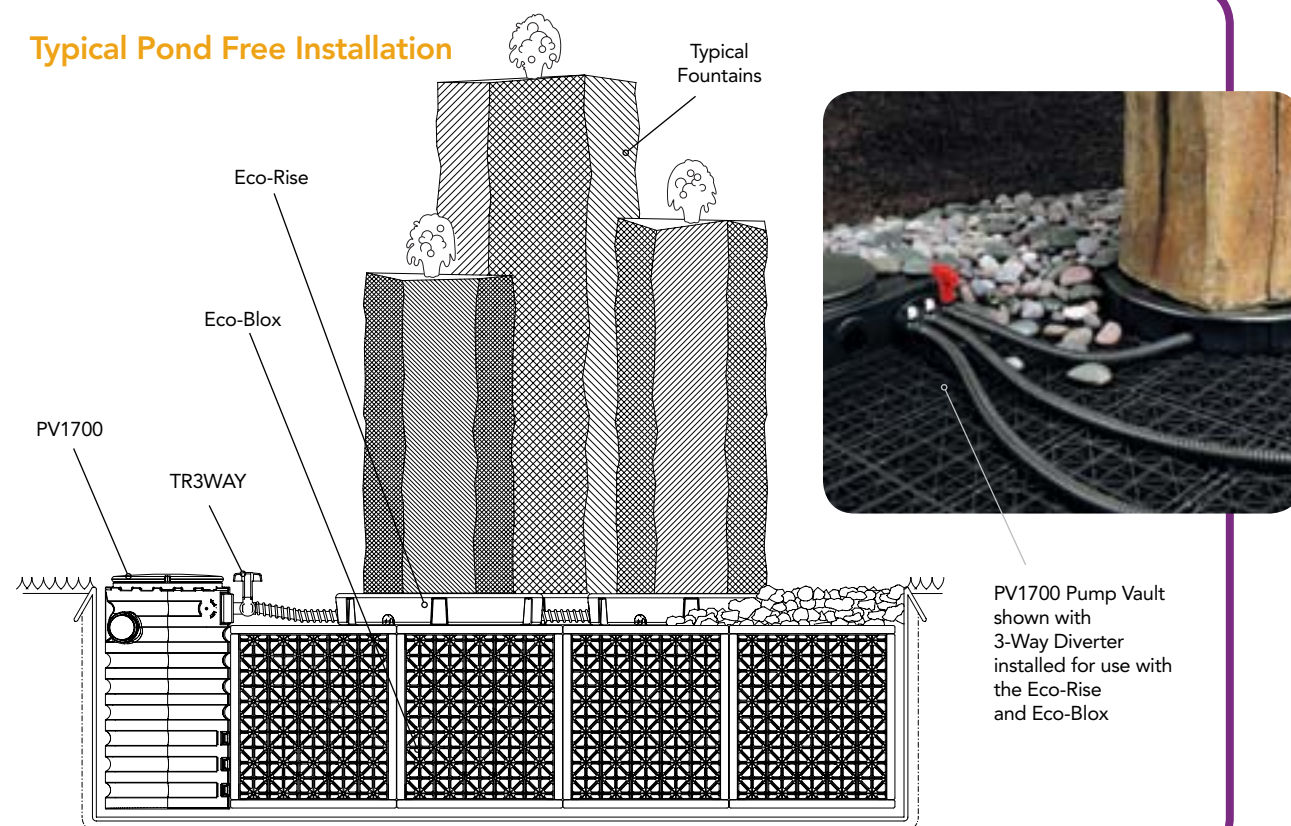

Pro Series Fountain Basin Model FB4600 Features:

1. One-piece construction provides exceptional strength.
2. Built-in channels simplify installation, allowing the plumbing to be run on top of the basin.
3. Seven molded cones support the top panel.
4. Recessed pocket accepts the Triton 3-Way Diverter. Adjusting the water flow to multiple pieces has never been easier.
5. Recessed 1 1/2" conduit recesses allow for clean installation in surrounding masonry without notching
6. Flat panel for optional AF1000 Auto Fill installation



INTERNAL CONE SUPPORT SYSTEM

NEW!

Pro Series Fountains

Bring the beauty of natural stone to your garden with Atlantic's NEW Bubbling Columns and Pebble Pots. Made from sturdy fiberglass, these elegant pieces eliminate weight and safety concerns while retaining all the charm and durability of natural rock. Lightweight and easy to plumb, these attractive pieces are the perfect complement to any garden.



NEW!

Pro Series Color Changing Fountains

Atlantic is proud to introduce a new concept in illuminated water features – overflowing vases that glow from within! During the day the three sizes create the welcome sights and sounds of dancing water, bubbling up and cascading down their sides – but in the dark, they come alive with light! Working on the same technology as our Color Changing Colorfalls, these vases radiate in 48 different colors, or in 16 different pre-programmed patterns, with speed and intensity regulated by Remote Control.

PRO SERIES

PRO SERIES

MODELS :

Model: FTN PP20
Description: Fiberglass Pebble Pot
Inlet: 3/4" insert fitting
Dimensions: 11"W x 20"H
For Use With: FB2400 Basin & FP300 pump

Model: FTN PP32
Description: Fiberglass Pebble Pot
Inlet: 3/4" insert fitting
Dimensions: 18"W x 32"H
For Use With: FB3200 Basin & FP400 pump

Model: FTN PP43
Description: Fiberglass Pebble Pot
Inlet: 3/4" insert fitting
Dimensions: 24"W x 43"H
For Use With: FB4600 Basin & FP500 pump



Add an AWGFT2 Fountain Light to combine a splash of warming light with the sound of water!

Model: FTN BC16
Description: Fiberglass Basalt Column
Inlet: 3/4" insert fitting
Dimensions: 9"W x 16"H
For Use With: FB2400 Basin & FP200 pump

Model: FTN BC30
Description: Fiberglass Basalt Column
Inlet: 3/4" insert fitting
Dimensions: 15"W x 30"H
For Use With: FB3200 Basin & FP400 pump

Model: FTN BC22
Description: Fiberglass Basalt Column
Inlet: 3/4" insert fitting
Dimensions: 12"W x 22"H
For Use With: FB3200 Basin & FP300 pump

Model: FTN BCX3
Description: 3pc. Basalt Column Kit
Inlet: (3) 3/4" insert fittings
Includes: FTN BC16, BC22 & BC30
For Use With: FB4600 Basin, FBKIT3 & MD1000 pump

A Totally New Concept in Ornamental Features - Color Changing Vases!

MODELS :

Model: FTN CCV18
Description: Color Changing Vase
Inlet: 3/4" PVC pipe
Dimensions: 10"W x 18"H
For Use With: FB2400 Basin, FBKIT1 & FP200 pump

Model: FTN CCV32
Description: Color Changing Vase
Inlet: 3/4" PVC pipe
Dimensions: 14"W x 32"H
For Use With: FB3200 Basin, FBKIT1 & FP400 pump

Model: FTN CCV24
Description: Color Changing Vase
Inlet: 3/4" PVC pipe
Dimensions: 12"W x 24"H
For Use With: FB3200 Basin, FBKIT1 & FP300 pump

Model: FTN CCVX3
Description: 3pc. Color Changing Vase Kit
Inlet: (3) 3/4" PVC pipe
Includes: FTN CCV18, CCV24 & CCV32
For Use With: FB4600 Basin, FBKIT3 & MD1000 pump



Color Changing Vases Feature:

- Color Changing LED Light Ring, Remote Control and Control Module
- Integrated anchor base for increased stability
- Durable rotomolded polyethylene construction
- Simulated granite finish
- Sold individually or as a 3-piece Kit



EACH COLOR CHANGING VASE INCLUDES LED LIGHT RING, SOL CONTROL MODULE & REMOTE

PATENT PENDING

Pro Series Kits



Our complete pond and pond-free kits offer a convenient, easy and affordable way to achieve a perfectly matched and balanced system. Detailed installation instructions are included.

PRO SERIES

Professional Pond-free Kits

- PV1800 Pump Vault
- Pro Series FastFalls
- TidalWave2 Pump
- Triton Check Valve
- 2" x 25' Flexible PVC Pipe

- 45 mil EPDM pond liner
- Heavy-duty Underlayment
- Eco-Blox
- AWGLED3 pond lights
- AF1000 Auto Fill
- Complete Installation Kit Including Glue, Cleaner, Thread Sealant & (3) 12oz. FallsFoam



Kit No.	Liner Size	FastFalls	Eco-Blox	Pump	Basin Size	Streambed
PK1819PL	10' x 15'	SP1900	3	TW3700	54" x 32" x 18"	19" - 24"W x 6'L
PK1826PL	10' x 20'	SP2600	5	TW4800	54" x 48" x 18"	26" - 32"W x 10'L

Professional Pond Kits (SMALL)

- PS4600 Pro Series Skimmer
- BF1900 Pro Series FilterFalls
- TW2 or PAF-Series Pump
- Triton Check Valve
- Flexible PVC Pipe
- 45 mil EPDM pond liner

- Heavy-duty Underlayment
- AWGLED3 pond lights
- AF1000 Auto Fill
- Complete Installation Kit Including Glue, Cleaner, Thread Sealant & (3) 12oz. FallsFoam



Kit No.	Pond Size	Liner Size	Pump	Hose Size
PK191015T	6' x 11'	10' x 15'	TW3700	2" x 25'
PK191515T	11' x 11'	15' x 15'	TW3700	2" x 25'
PK191520T	11' x 16'	15' x 20'	TW3700	2" x 25'
PK191015P	6' x 11'	10' x 15'	PAF-20	2" x 25'
PK191515P	11' x 11'	15' x 15'	PAF-20	2" x 25'
PK191520P	11' x 16'	15' x 20'	PAF-20	2" x 25'

Professional Pond Kits (MEDIUM)

- PS7000 Pro Series Skimmer
- BF2600 Pro Series FilterFalls
- TW2 or PAF-Series Pump
- Triton Check Valve
- Flexible PVC Pipe
- 45 mil EPDM pond liner

- Heavy-duty Underlayment
- AWGLED3 pond lights
- AF1000 Auto Fill
- Complete Installation Kit Including Glue, Cleaner, Thread Sealant & (3) 12oz. FallsFoam



Kit No.	Pond Size	Liner Size	Pump	Hose Size
LPK261515T	11' x 11'	15' x 15'	TW4800	2" x 25'
PK261520T	11' x 16'	15' x 20'	TW4800	2" x 25'
PK262020T	16' x 16'	20' x 20'	TW4800	2" x 25'
PK261515P	11' x 11'	15' x 15'	PAF-25	2" x 25'
PK261520P	11' x 16'	15' x 20'	PAF-25	2" x 25'
PK262020P	16' x 16'	20' x 20'	PAF-25	2" x 25'

Professional Pond Kits (LARGE)

- PS15000 Pro Series Skimmer
- BF3800 Pro Series FilterFalls
- PAF or A-Series Pump
- Triton Check Valve
- Flexible PVC Pipe
- 45 mil EPDM pond liner

- Heavy-duty Underlayment
- AWGLED3 pond lights
- AF1000 Auto Fill
- Complete Installation Kit Including Glue, Cleaner, Thread Sealant & (3) 12oz. FallsFoam



All Large Professional Pond Kits measure 42"L x 36"H x 48"D and are supplied on a pallet

Kit No.	Pond Size	Liner Size	Pump	Hose Size
PK381520P	11' x 16'	15' x 20'	PAF-75	2" x 50'
PK382020P	16' x 16'	20' x 20'	PAF-75	2" x 50'
PK382025A	16' x 21'	20' x 25'	A-31	3" x 50'
PK382530A	21' x 26'	25' x 30'	A-31	3" x 50'

TidalWave

PUMP PROTECTOR

The easiest way to damage a pump is to run it while it is not fully submersed in water. Water levels can be difficult to monitor, especially when the pump is hidden away inside a pump vault or skimmer box, where clogged filtration can restrict water flow, leading to low water levels or even causing the pump to run dry. Enter Atlantic's Tidal Wave Pump Protector, which will automatically shut off a pump before it can be damaged.



TidalWave

FOUNTAIN PUMP SERIES

Atlantic's Fountain Pumps offer everything you want in a small pump line, with large, sturdy pre-filters, integrated flow controls, versatile base plates and small diameter power plugs. Sized to fit even the smallest applications, these pumps still deliver big performance, with higher head heights and lower wattages than the competition. Trust Atlantic for all your fountain pump needs!

TIDALWAVE

TIDALWAVE

No Cycling On & Off!

Unlike water level sensors and built-in thermal protectors, which can cycle on and off repeatedly, ultimately allowing pump failure, the TidalWave Pump Protector electronically monitors subtle line power changes that are created by the pump during adverse load conditions. When the current change exceeds a pre-set internal threshold, power to the pump is cut off until physically reset. There is no cycling on and off like with float sensors that reset themselves. The TidalWave Pump Protector installs easily and instantly calibrates to any pump.

Pump Protector Features:

- Simple installation, no wiring
- Calibration/Reset Button
- Warning Buzzer
- Power Cut-off on fault
- Works with existing GFI
- 1-year warranty



Model: **TWPP14**
Input Voltage: 120 VAC
Max Amps: 14

Protects Against:

- Operating Dry
- Current Spikes
- Current Drop
- Thermal Cycling
- Low Water Flow



MODELS:

Model: **FP100**
Volts: 115
Watts: 7
Outlet: 1/2" MIPT
Cord: 6'
Dimensions: 3 1/2"L x 2 1/4"W x 2 1/2"H
Includes: Adjustable flow pre-filter & 1/2" - 3/4" outlet fitting

Model: **FP200**
Volts: 115
Watts: 9.5
Outlet: 1/2" MIPT
Cord: 6'
Dimensions: 3 1/2"L x 2 1/4"W x 2 1/2"H
Includes: Adjustable flow pre-filter & 1/2" - 3/4" outlet fitting

Model: **FP300**
Volts: 115
Watts: 16
Outlet: 1/2" FIPT
Cord: 16'
Dimensions: 5"L x 3"W x 3 1/4"H
Includes: Adjustable flow pre-filter & 1/2" - 3/4" outlet fitting

Model: **FP400**
Volts: 115
Watts: 24
Outlet: 1/2" FIPT
Cord: 16'
Dimensions: 5"L x 3"W x 3 1/4"H
Includes: Adjustable flow pre-filter & 1/2" - 3/4" outlet fitting

Model: **FP500**
Volts: 115
Watts: 33
Outlet: 1/2" FIPT
Cord: 16'
Dimensions: 5 1/4"L x 3 1/2"W x 4"H
Includes: Adjustable flow pre-filter & 1/2" - 3/4" outlet fitting

Fountain Pump Features:

- Removable pre-filter
- Integrated flow adjustment
- Replaceable impeller
- 1-year warranty

* Wattage is calculated @ BEP using the following formula (Volts x Amps x PF = Watts).

Model #	Watts	Max	2.5'	5'	7.5'
FP100	7	120			
FP200	9.5	175	100		
FP300	16	325	230	90	
FP400	24	370	290	180	
FP500	33	525	430	300	75

Best Efficiency Range

TidalWave

MAG DRIVE SERIES

TidalWave magnetic induction pumps are the perfect choice for small water features with low head heights. Hefty and heavy-duty, equipped with removable pre-filters, oversize ceramic shafts, replaceable impeller assemblies and a 20' power cord, Atlantic Mag Drives are the ones you've been waiting for. With great energy efficiency and a five-year warranty, these pumps are winners!



NEW!

TidalWave Fountain Heads

Add another dimension to your water garden with Atlantic's all new Fountain Heads. Compatible with all of Atlantic's Mag Drive Pumps, these versatile Fountain Heads pivot to make leveling easy, telescope to adjustable heights and feature four different spray patterns to choose from.

Model: MDFH2575

Description: Telescoping Fountain Head
 Min Height: 12"
 Max Height: 18"
 Inlet: 3/4" FIPT
 Outlet: 1/2" insert
 For Use With: 250 - 750 gph MD pumps
 Includes: Telescoping diverter w/ 4 interchangeable fountain heads

Model: MDFH1020

Description: Telescoping Fountain Head
 Min Height: 15"
 Max Height: 22"
 Inlet: 1" FIPT
 Outlet: 1" MIPT
 For Use With: 1000 - 2000 gph MD pumps
 Includes: Telescoping diverter w/ 4 interchangeable fountain heads

TIDALWAVE

TIDALWAVE



MODELS:

Model: MD250 **NEW!**
 Volts: 115
 Watts: 15
 Inlet: 1" MIPT
 Outlet: 3/4" MIPT
 Dimensions: 4 1/2" L x 3 1/2" W x 5" H
 Includes: Pre-filter, 3/4" - 1" outlet fitting

Model: MD350
 Volts: 115
 Watts: 25
 Inlet: 1" MIPT
 Outlet: 3/4" MIPT
 Dimensions: 4 1/2" L x 3 1/2" W x 5" H
 Includes: Pre-filter, 3/4" - 1" outlet fitting

Model: MD550
 Volts: 115
 Watts: 40
 Inlet: 1" MIPT
 Outlet: 3/4" MIPT
 Dimensions: 4 1/2" L x 3 1/2" W x 5" H
 Includes: Pre-filter, 3/4" - 1" outlet fitting

Model: MD750
 Volts: 115
 Watts: 50
 Inlet: 1" MIPT
 Outlet: 3/4" MIPT
 Dimensions: 4 1/2" L x 3 1/2" W x 5" H
 Includes: Pre-filter, 3/4" - 1" outlet fitting

Model: MD1000
 Volts: 115
 Watts: 90
 Inlet: 1 1/2" MIPT
 Outlet: 1" MIPT
 Dimensions: 5 1/2" L x 4 1/4" W x 5 1/2" H
 Includes: Pre-filter, 1" - 1 1/2" outlet fitting

Model: MD1250
 Volts: 115
 Watts: 120
 Inlet: 1 1/2" MIPT
 Outlet: 1" MIPT
 Dimensions: 5 1/2" L x 4 1/4" W x 5 1/2" H
 Includes: Pre-filter, 1" - 1 1/2" outlet fitting

Model: MD1500
 Volts: 115
 Watts: 165
 Inlet: 1 1/2" MIPT
 Outlet: 1" MIPT
 Dimensions: 6" L x 4 3/4" W x 6" H
 Includes: Pre-filter, 1" - 1 1/2" outlet fitting

Model: MD2000
 Volts: 115
 Watts: 250
 Inlet: 1 1/2" MIPT
 Outlet: 1" MIPT
 Dimensions: 6" L x 4 3/4" W x 6" H
 Includes: Pre-filter, 1" - 1 1/2" outlet fitting

Model #	Watts	Max	5'	10'	15'	20'	25'	30'
		300	145					
MD250	15	300						
MD350	25	370	145					
MD550	40	650	385					
MD750	50	790	465					
MD1000	90	1080	785	275				
MD1250	120	1330	1040	580				
MD1500	165	1560	1255	780				
MD2000	250	2010	1695	1320	695			

Recommended Operating Range Best Efficiency Point Do Not Operate Range

* Wattage is calculated @ BEP using the following formula (Volts x Amps x PF = Watts).

Mag Drive Pumps Feature: (MD1500 shown)

- Oversized male threaded inlet and outlet for less restriction and greater flow
- Rotating volute provides maximum adaptability for any installation
- Half twist volute provides access to the impeller assembly without the use of tools
- Large, stable base is removable for added versatility
- Removable pre-filter provides increased surface area and reduces maintenance
- Tapered outlet fittings accept a wide array of tubing sizes
- MD1000 - MD2000 include a 1 1/2" adapter for use with the Triton Check Valve and Fountain Basin Plumbing Kits (not shown)

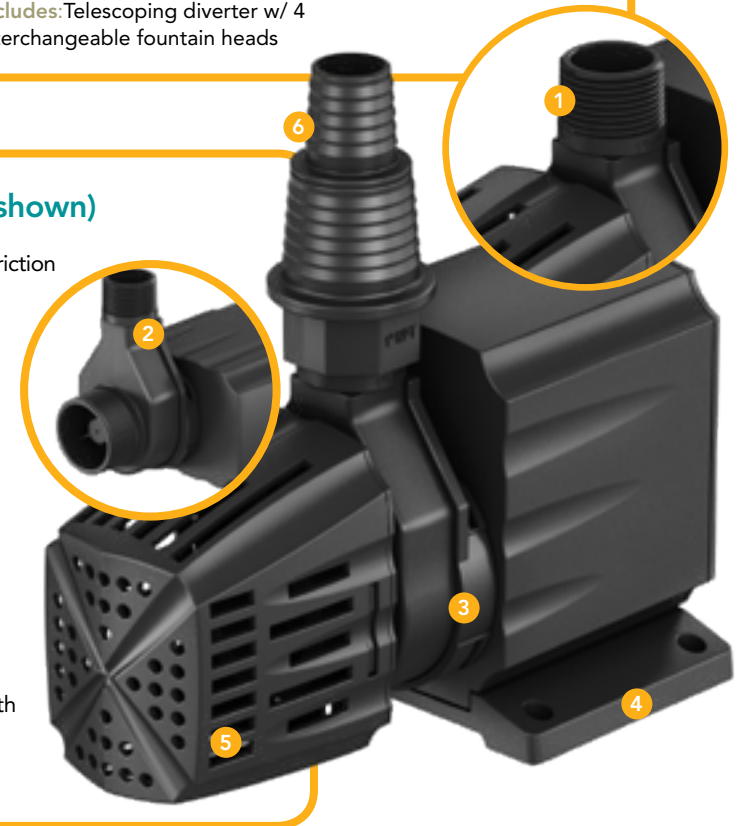

TidalWave²

HYBRID PUMP SERIES

TidalWave2 asynchronous pumps are the perfect choice for high flow, medium head applications where energy consumption is a factor. Efficient vortex impellers driven by asynchronous magnetic induction provide great hybrid performance, delivering direct drive output at magnetic drive efficiency. Compact, powerful TidalWave2 Hybrid Pumps offer the best of both worlds.

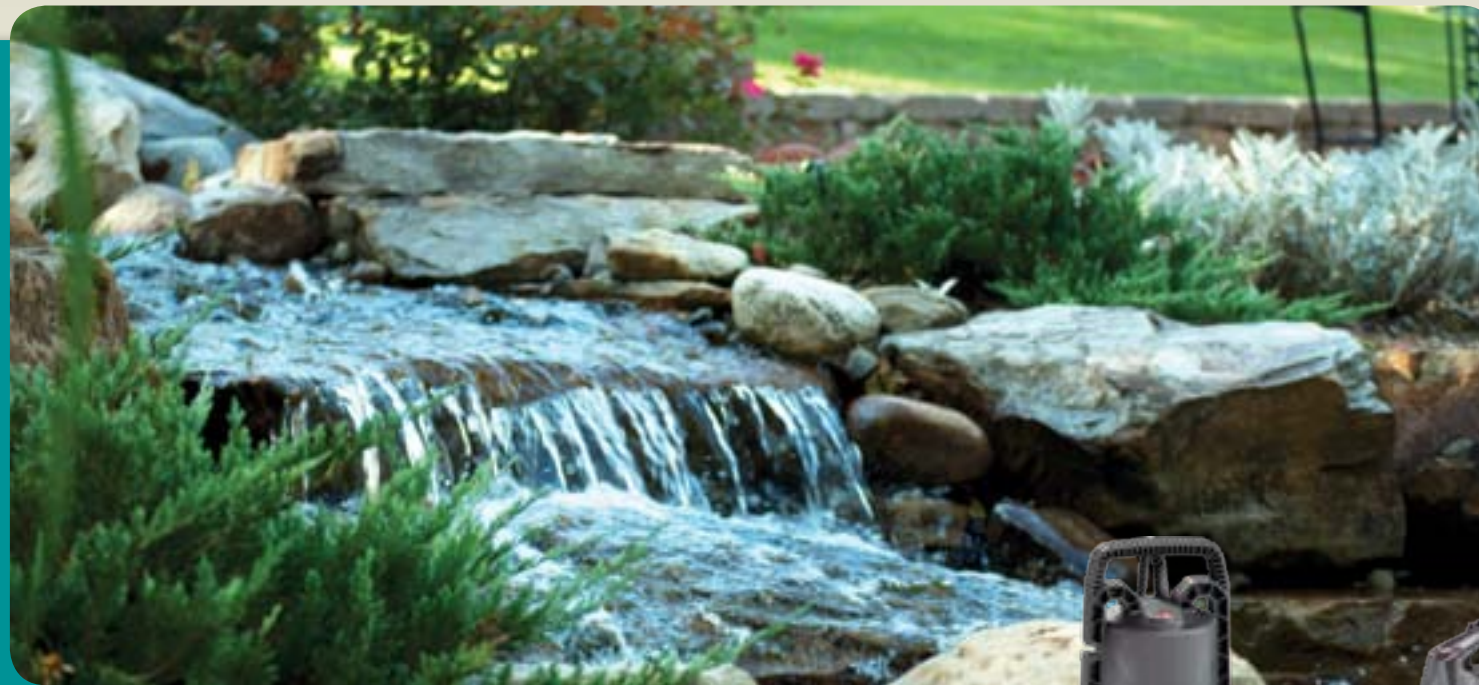

TidalWave

SH-SERIES PUMPS

A mainstay of the Water Garden Industry, TidalWave SH-Series Pumps have proven to be one of the most dependable and energy-efficient composite direct drives available. With true solids handling capacities of up to 1½" and stable base geometry, these value-packed pumps excel under the most rigorous conditions.

TIDALWAVE

TIDALWAVE



TidalWave2 Series Pump Features:

- Epoxy encapsulated asynchronous motor
- Vortex impeller
- Wear-proof ceramic shaft
- 32' power cord
- 2-year warranty



Model #	Watts	Max	5'	10'	15'	20'	25'	30'
TW1200	110	1290	1080	720	180			
TW1900	130	1900	1440	900	360			
TW2400	175	2400	1950	1390	825	220		
TW3700	355	3730	3010	2230	1425	660		
TW4800	425	4800	4000	3140	2228	1260	240	
TW6000	495	6000	5040	4050	3000	1930	852	

* Wattage is calculated @ BEP using the following formula (Volts x Amps x PF = Watts).

MODELS :

Model: TW1200
Volts: 115
Amps: 0.9
Watts: 110
Inlet: 1½" MIPT
Outlet: 1½" FIPT
Dimensions: 8½"L x 5"W x 6"H

Model: TW1900
Volts: 115
Amps: 1.1
Watts: 130
Inlet: 1½" MIPT
Outlet: 1½" FIPT
Dimensions: 8½"L x 5"W x 6"H

Model: TW2400
Volts: 115
Amps: 1.45
Watts: 175
Inlet: 1½" MIPT
Outlet: 1½" FIPT
Dimensions: 8½"L x 5"W x 6"H

Model: TW3700
Volts: 115
Amps: 2.95
Watts: 355
Inlet: 2" MIPT
Outlet: 1½" FIPT
Dimensions: 10"L x 6"W x 7"H

Model: TW4800
Volts: 115
Amps: 3.55
Watts: 425
Inlet: 2" MIPT
Outlet: 1½" FIPT
Dimensions: 10"L x 6"W x 7"H

Model: TW6000
Volts: 115
Amps: 4.15
Watts: 495
Inlet: 2" MIPT
Outlet: 2" FIPT
Dimensions: 10"L x 6"W x 7"H

Recommended Operating Range Best Efficiency Point Do Not Operate Range



TidalWave SH-Series Pump Features:

- Non-corrosive and handles solids
- Oil-Free design
- Vortex Impeller
- Overload and thermal protection
- 16' power cord
- 2-year warranty



Model #	Watts	Max	5'	10'	15'	20'	25'	30'	35'
SH1450	240	1450	1170	650					
SH2050	320	2050	1700	1130	235				
SH3600	575	3600	3245	2750	2090	1210			
SH5000	950	5000	4350	3620	2800	1875	825		
SH6500	1000	6500	5710	4875	4000	3080	2110	1085	

* Wattage is calculated @ BEP using the following formula (Volts x Amps x PF = Watts).

MODELS :

Model: SH1450
Volts: 115
Amps: 2.1
Watts: 240
Outlet: 1¼" FIPT w/ 1½" FIPT elbow
Dimensions: 6"L x 9"W x 11¾"H

Model: SH2050
Volts: 115
Amps: 2.8
Watts: 320
Outlet: 1¼" FIPT w/ 1½" FIPT elbow
Dimensions: 6"L x 9"W x 12½"H

Model: SH3600
Volts: 115
Amps: 5.5
Watts: 575
Outlet: 1¼" FIPT w/ 1½" FIPT elbow
Dimensions: 6"L x 9"W x 14"H

Model: SH5000
Volts: 115
Amps: 9
Watts: 950
Outlet: 1½" FIPT w/ 1½" FIPT elbow
Dimensions: 9½"L x 12"W x 15¾"H

Recommended Operating Range Best Efficiency Point Do Not Operate Range

*Operating pumps outside of the recommended range may cause bearing damage and premature failure.

TidalWave

PAF PUMP SERIES

Lightweight, energy efficient and corrosion resistant, TidalWave PAF Series Pumps are now even more versatile, with a removable intake screen for conversion to true 1¼" solids handling capacity. Sharing the same high quality internal components as our A-Series, PAF direct drive pumps are perfect for demanding medium head, high volume applications.



TidalWave

SERIES PUMPS

TidalWave A-Series & L-Series Pumps are manufactured from cast iron and stainless steel with precision motors and thermal overload protection. These professional-grade pumps are engineered for high volume applications and perform where most cannot. All models feature double silicon carbide mechanical seals, dual drive bearings, Auto-cut thermal protection, 30' power cord and a 2-year warranty.

TIDALWAVE

TIDALWAVE



TidalWave PAF Series Pump Features:

- Stainless steel and composite construction
- Double silicon carbide mechanical seals
- Fiber reinforced vortex impeller
- 20' power cord
- 2-year warranty



Removable screen for solids handling capability

* Wattage is calculated @ BEP using the following formula (Volts x Amps x PF = Watts).

MODELS:

Model: **PAF-20**
 Motor: 1/4 HP
 Volts: 115
 Amps: 3.5
 Watts: 360
 Outlet: 2" FIPT
 Dimensions: 9"L x 6"W x 14"H

Model: **PAF-25**
 Motor: 1/3 HP
 Volts: 115
 Amps: 5
 Watts: 545
 Outlet: 2" FIPT
 Dimensions: 9"L x 6"W x 14½"H



Model #	Watts	Max	5'	10'	15'	20'	25'	30'	35'
PAF-20	360	--	2800	1950	1080	180			
PAF-25	545	--	3900	3150	2300	1350	240		
PAF-40	650	--	4950	4350	3570	2700	1700	520	
PAF-75	900	--	5950	5270	4560	3750	2830	1770	550

*Operating pumps outside of the recommended range may cause bearing damage and premature failure.

Recommended Operating Range Best Efficiency Point Do Not Operate Range

Model: **PAF-40**
 Motor: 1/2 HP
 Volts: 115
 Amps: 6
 Watts: 650
 Outlet: 2" FIPT
 Dimensions: 9"L x 6"W x 15"H

Model: **PAF-75**
 Motor: 1 HP
 Volts: 115
 Amps: 8.5
 Watts: 900
 Outlet: 2" FIPT
 Dimensions: 9"L x 6"W x 16"H



TidalWave A-Series Pump Features:

- High-head / High-volume, direct-drive pumps
- Cast iron vortex impeller

TidalWave L-Series Pump Features:

- Low-head / High-volume, axial flow pumps
- Energy efficient / low power consumption

* Wattage is calculated @ BEP using the following formula (Volts x Amps x PF = Watts).

MODELS:

Model: **A-05** Motor: 1/2 HP
 Volts: 115 Amps: 5.7
 Watts: 645 Outlet: 2" FIPT
 Weight: 32 lbs.
 Dimensions: 9"L x 6¼"W x 15"H

Model: **A-05L** Motor: 1/2 HP
 Volts: 115 Amps: 6.6
 Watts: 725 Outlet: 2" FIPT
 Weight: 40 lbs.
 Dimensions: 10"L x 7"W x 17"H

Model: **A-21** Motor: 1 HP
 Volts: 115 Amps: 9.6
 Watts: 1060 Outlet: 2" FIPT
 Weight: 43 lbs.
 Dimensions: 10"L x 7"W x 17"H

Model #	Watts	Recommended Operating Range										Best Efficiency Point		Do Not Operate Range			
		Max	5'	10'	15'	20'	25'	30'	35'	40'	45'	50'	55'	60'			
A-05	645	--	3165	2840	2500	2155	1875	1455	935	320							
A-05L	725	--	5040	4320	3600	2820	1920	840									
A-21	1060	--	5810	5325	4824	4335	3770	3140	2400	1530	540						
A-31	1160	--	9300	8150	6830	5535	4120	2535	625								
A-32	2055	--	12000	11040	10440	9780	9000	8280	7560	6780	5580	4920	3890				
L-305	710	--	10380	7380	3960												
L-310	1105	--	13500	10560	7380	3240											

*Operating pumps outside of the recommended range may cause bearing damage and premature failure.

Model: **A-31** Motor: 1 HP
 Volts: 115 Amps: 10.3
 Watts: 1160 Outlet: 3" FIPT
 Weight: 48 lbs.
 Dimensions: 11"L x 7"W x 18"H

Model: **A-32** Motor: 2 HP
 Volts: 230 Amps: 9.4
 Watts: 2055 Outlet: 3" FIPT
 Weight: 95 lbs.
 Dimensions: 15"L x 8½"W x 23"H

Model: **L-305** Motor: 1/2 HP
 Volts: 115 Amps: 6.4
 Watts: 710 Outlet: 3" MPT
 Weight: 60 lbs.
 Dimensions: 9"L x 9"W x 19¼"H

Model: **L-310** Motor: 1 HP
 Volts: 115 Amps: 10
 Watts: 1105 Outlet: 3" MPT
 Weight: 65 lbs.
 Dimensions: 9"L x 9"W x 19¼"H

Installation Products

Designed with you in mind to make installation and adjustment easier, Atlantic has everything you need to install water features. Featuring products like 45mil EPDM liner, FallsFoam, flexible PVC pipe, RTV silicone, AF1000 Auto Fill and Sch 40 fittings that are proudly manufactured in the USA to the highest standards, Atlantic installation accessories stand the test of time and keep your water feature running for years.

Check Valves

Triton Check Valve with Pumps:



NOTE the Triton Check Valve will work with all 1 1/2" & 2" discharge TidalWave pumps, and all Atlantic equipment. The discharge pipe must be extended using 2" PVC pipe and a slip x slip coupling when installed within the PV2300, PS15000 or if Pump Vault extensions are used.

Check Valve with TidalWave A-Series Pump:



Triton™ Check Valve

Atlantic's award winning Triton Check Valve is the only check valve designed exclusively for the water garden industry. The 'swing style' Triton Check Valve features a 2" socket union on the inlet, 2" and 1 1/2" socket unions for the outlet, a molded-in 90° elbow, and a slim design that allows clearance when installed with direct drive pumps. If simplicity and innovation is what you seek, Triton delivers!

Model: **TR215CV**

Valve Dimensions: 5 5/8" L x 3 1/2" W x 10" H

Inlet: 2" socket

Outlet: 1 1/2" or 2" Sch 40 socket

Pipe Dimension: 11 7/8" L x 2 5/8" W

Inlet: 1 1/2" or 2" MIPT

Outlet: 2" Sch 40 pipe

Includes: 2" check valve with unions, 1 1/2" outlet fitting, and discharge pipe



Triton Check Valve Features:

- Molded "perfect-cut" dimensions to identify proper lengths for Atlantic products and cut-to-fit 1" increments on the reverse side
- Maximum assembled height of 17" (from the pump discharge to the center of the outlet pipe)
- Works with all 1 1/2" and 2" pump outlets
- Can be extended to any length using 2" Sch 40 fittings

3" Check Valve

Atlantic's AWGCV30 features a full flow 3" 'swing style' check valve with an offset valve body, 90° elbow and a 3" rubber coupling on the outlet. A 3" pump discharge pipe (**not included**) can be extended to any length using 3" PVC.



Model: **AWGCV30**

Valve Dimensions: 11 1/2" L x 5 1/2" W x 13 1/2" H

Inlet: 3" socket

Outlet: 3" rubber coupling



FallsFoam, Sealant & Auto Fill



FallsFoam

FallsFoam is an expandable foam sealant used to stabilize stones, fill voids and seal joints during waterfall construction. 12oz. DIY FallsFoam is perfect for homeowner projects, while 29oz. FallsFoam cartridges and foam guns are indispensable tools for professionals.

MODELS :

Model: LF1000
Description: 12 oz. can DIY black waterfall foam

Model: LF1300
Description: 29 oz. can Professional black waterfall foam

Model: LF1310
Description: Professional foam gun (alloy, for use with 29 oz. cans)

Model: LF1315
Description: Professional foam gun (composite, for use with 29 oz. cans)

Model: LF1325
Description: 12 oz. can foam gun cleaner



Tubing & Fittings

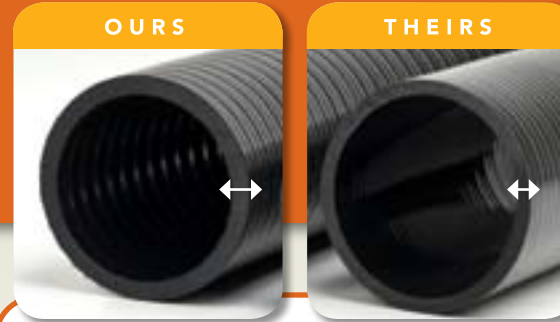

Flexible PVC Piping

Think all flexible PVC piping is the same? Take a closer look... Atlantic's PVC piping is heavy walled, extremely flexible and incredibly durable. Decrease labor, maximize pump flow and eliminate call-backs with flexible PVC piping from Atlantic.

MODELS :

Model: FH1525
Description: 1½" x 25' PVC black flex pipe

Model: FH1550
Description: 1½" x 50' PVC black flex pipe

Model: FH225
Description: 2" x 25' PVC black flex pipe

Model: FH250
Description: 2" x 50' PVC black flex pipe

Model: FH350
Description: 3" x 50' PVC black flex pipe



RTV Silicone Sealant

Black RTV silicone sealant is used to create a watertight seal where liner is attached to filtration components. Permanently flexible RTV silicone used in conjunction with Atlantic's molded inserts, liner retention flanges and stainless steel hardware ensures a watertight connection every time.



MODELS :

Model: SN2800
Description: 2.8 oz. tube black RTV silicone

Model: SN10300
Description: 10.3 oz. cartridge black RTV silicone



Auto Fill

Maintain a consistent water level in all Atlantic Skimmers, Pump Vaults, Colorfalls and Fountain Basins by installing an Auto Fill valve. Atlantic's AF1000 Auto Fill kits include fittings to connect to a water supply using standard garden hose, ½" irrigation line and ½" Sch 40 PVC.

MODEL :

Model: AF1000
Description: ½" MIPT Auto Fill valve



Atlantic also offers a full array of Firestone 'Pond Guard' Liner rolls, boxed liner and installation accessories. We offer heavy duty pond underlayment in full rolls and pre-cut sizes. Please contact Atlantic or see price list for details.

Fittings

MODELS :

Model: HA1550
Description: Bulkhead ½" FIPT

Model: HA2000
Description: Bulkhead 2" FIPT

Model: HA3000
Description: Bulkhead 3" FIPT

Model: 436-015
Description: ½" Male Thread Adaptor (MIPT x Slip)

Model: 436-020
Description: 2" Male Thread Adaptor (MIPT x Slip)

Model: 436-030
Description: 3" Male Thread Adaptor (MIPT x Slip)

Model: 429-015
Description: ½" Coupler (Slip x Slip)

Model: 406-015
Description: 1½" 90° (Slip x Slip)

Model: 429-020
Description: 2" Coupler (Slip x Slip)

Model: 406-020
Description: 2" 90° (Slip x Slip)

Model: 429-030
Description: 3" Coupler (Slip x Slip)

Model: 406-030
Description: 3" 90° (Slip x Slip)



Lighting Products

Enjoy your water features deep into the night with Atlantic's LED lighting systems. Featuring ALL NEW brass-bodied SOL Lights, in both Warm White and Color Changing varieties, Atlantic's low energy consumption LED lights give your space a welcome warming glow, above ground or under water, all night long. Atlantic SOL lighting is long-lasting, energy-efficient and carries a one-year warranty.



Outdoor LED Lighting SOLUTIONS

SOL AWG Lighting

Featuring built-in photo cells that automatically turn lights on at dusk and off at dawn, Atlantic's AWG line of LED lights eliminate the need for timers and switches. AWG LED lights can be used both underwater and in open air applications, and are available in large, small and fountain light sizes.

MODELS :



Model: AWGLED1
Description: Single Warm White Pond Light w/quick connect plug
Voltage: 12 volt AC
Watts: 1.6
Includes: Light base, photo cell, ground stake, outdoor transformer & 22' power cord



Model: AWGLED3
Description: 3 Pack Warm White Pond Light w/quick connect plug
Voltage: 12 volt AC
Watts: 4.8
Includes: Light bases (3), photo cell, ground stake, transformer and 22' power cord - 3½' cord between lights



Model: AWGLEDLG
Description: Large Single Warm White Pond Light w/quick connect plug
Voltage: 12 volt AC
Watts: 4.8
Includes: Light base, photo cell, ground stake, transformer and 22' power cord



Model: AWGFT2
Description: Warm White Fountain Light
Voltage: 12 volt AC
Watts: 1.5
Includes: LED Fountain Light, ½" MPT x ¾" insert fitting, outdoor transformer & 20' power cord

NEW!

SOL LED Lighting

Atlantic's all new SOL Lighting features solid brass bodies with an oil rubbed bronze finish that adds class to your application while reducing the heat emitted. Available in both 2 watt and 6 watt warm white bullet styles and in a Light Ring perfect for fountains and waterfalls, these lights are a great way to enjoy your water feature after the sun goes down.



NEW!

SOL Color Changing Lighting

For those looking to bring more than just a warming glow to your evening, Atlantic's all new Color Changing SOL LEDs are the solution. Just like our popular Color Changing Colorfalls, these LEDs create a vibrant nighttime atmosphere with 48 different colors and 16 different color changing combinations. Multiple LEDs can be connected to be run through one transformer and be controlled together, all by remote!

MODELS :



Model: SOLW2
Description: Compact Warm White Spotlight
Input Voltage: 12 volt AC
Watts: 2
Includes: LED Spotlight, 20' power cord w/ quick-connect plug, stand and ground stake



Model: SOLW6
Description: Warm White Spotlight
Input Voltage: 12 volt AC
Watts: 6
Includes: LED Spotlight, 20' power cord w/ quick-connect plug, stand and ground stake



Model: SOLWLR
Description: Warm White Light Ring
Input Voltage: 12 volt AC
Watts: 10
Includes: LED Light Ring, 20' power cord w/ quick-connect plug

MODELS :



Model: SOLCC2
Description: Compact Color Changing Spotlight
Input Voltage: 12 volt DC
Watts: 1 - 2.5 variable
Includes: Color Changing LED Spotlight, 20' power cord w/ quick-connect plug, stand and ground stake



Model: SOLCC6
Description: Color Changing Spotlight
Input Voltage: 12 volt DC
Watts: 3 - 7.5 variable
Includes: Color Changing LED Spotlight, 20' power cord w/ quick-connect plug, stand and ground stake



Model: SOLCCLR
Description: Color Changing Light Ring
Input Voltage: 12 volt DC
Watts: 2 - 6 variable
Includes: Color Changing LED Light Ring, 20' power cord w/ quick-connect plug



Model: SOL20X4
Description: Transformer and 4-way Splitter
For Use With: Warm White AWG and SOL Lighting
Voltage: 12 volt AC / 2-wire
Watts: 20
Includes: Transformer and 4-way splitter w/ quick-connect plugs



Model: SOLWEXT
Description: 20' 2-wire Extension Cord
For Use With: Warm White AWG and SOL Lighting



Model: SOLCCMX3
Description: SOL Color Changing Control Module
For Use With: Color Changing SOL Lighting
Input Voltage: 12 volt AC
Output Voltage: 12 volt DC / 6-wire
Includes: 24 watt transformer, 3-way splitter, Control Module and Remote Control

NOT COMPATIBLE WITH COLOR CHANGING COLORFALLS



Model: SOLCCEXT
Description: 20' 6-wire Extension Cord
For Use With: Color Changing SOL Lighting



SOL20X4 and SOLWEXT are fully compatible with all AWG LEDs found on page 49.

LIGHTING

LIGHTING

Accessory Products

Whether beautifying your ponds with cosmetic accessories like rock lids, protecting your fish with a Gate Keeper, or choosing the right filtration for your setup with a Brush Kit or Matala Mat Kit, Atlantic's accessories allow you to upgrade and customize your Skimmers and FilterFalls to fit your specific water feature.

Rock Lids

Rock Lids come in four regional colors:



Desert

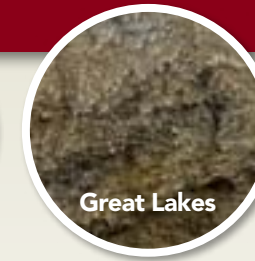

Great Lakes

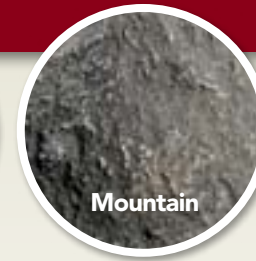

Mountain

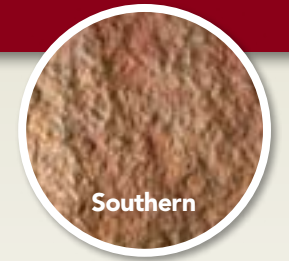

Southern

Say goodbye to that plastic "fake rock" look forever with Atlantic's realistic Rock Lids. Molded from real stones, the sturdy fiberglass construction, authentic textures and incredibly real finishes set these Rock Lids apart from anything else available today. Three sizes and four regional colors ensure the perfect fit for every application. No one will ever know it's not real!

MODELS : Color representations shown may vary on actual product.

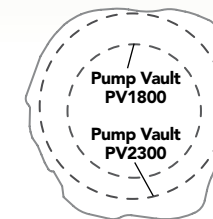

RL30 Footprint

Model: RL30G Great Lakes
 RL30D Desert
 RL30M Mountain
 RL30S Southern
Dimensions: 24"L x 24"W x 5"H
Match to Skimmer: PS3900
Match to Pump Vault: PV1800 / PV2300 / RHPV

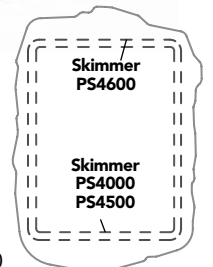

RL40 Footprint

Model: RL40G Great Lakes
 RL40D Desert
 RL40M Mountain
 RL40S Southern
Dimensions: 34"L x 24"W x 5"H
Match to Skimmer: PS4000 / PS4500 / PS4600

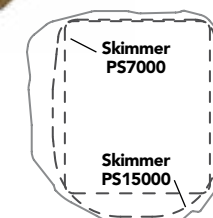

RL70 Footprint

Model: RL70G Great Lakes
 RL70D Desert
 RL70M Mountain
 RL70S Southern
Dimensions: 40"L x 36"W x 10"H
Match to Skimmer: PS7000 / PS15000

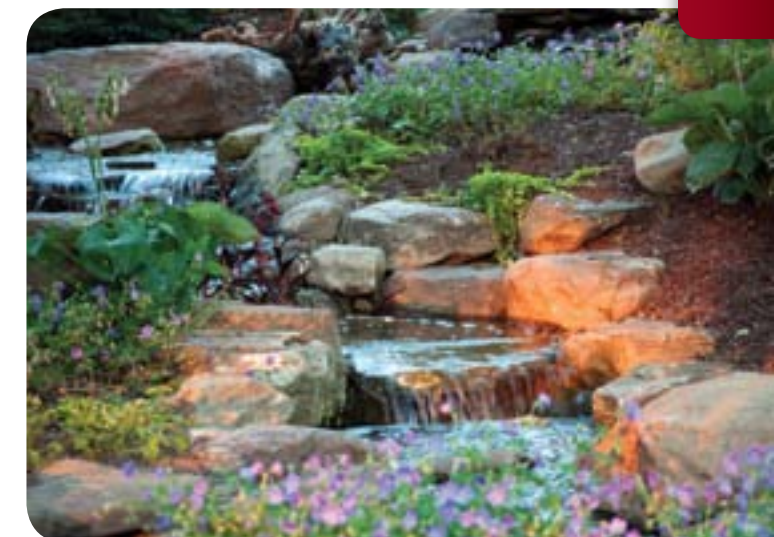

Skimmer Accessories



Gate Keepers

Gate Keepers attach to the Skimmer weir to protect your valuable fish by keeping them from swimming into your Skimmer, while still allowing water to pass through.

MODELS :

Model: GK600
Description: Gate Keeper for 6" Super Flow Weir Doors

Model: GK900
Description: Gate Keeper for 9" Super Flow Weir Doors

Model: GK1400
Description: Gate Keeper for 14" Super Flow Weir Doors



Brush Kits

Atlantic's innovative Skimmer Brush Panels provide exceptional debris removal, and unlike dense filter pads, will not block water flow to the pump if neglected. All Pro Series Skimmers can accept an additional brush panel to increase mechanical filtration. Stainless steel and polypropylene construction provide maximum durability.

MODELS :

Model: BK4600
Description: PS4600 Skimmer Brush Kit

Model: BK7000
Description: PS7000 Skimmer Brush Kit

Model: BK15000
Description: PS15000 Skimmer Brush Kit



Bottom Drain Kit

A Bottom Drain Kit in your Skimmer makes it easy to keep sludge at bay by pulling debris from the bottom of your pond while the Super Flow weir door skims debris from the surface.

MODEL :

Model: BD2000
Description: Bottom Drain Kit for all Skimmers



Matala Mat Kits

When used in conjunction with the standard Skimmer Net and Brush Panel, Matala Mat Kits create three-stage mechanical filtration that reduces maintenance and extends the time between skimmer cleaning. Mat Kits fit all Pro Series Skimmers.

MODELS :

Model: MK4600
Description: PS4600 Matala Mat Kit with support frame

Model: MK7000
Description: PS7000 Matala Mat Kit with support frame

Model: MK15000
Description: PS15000 Matala Mat Kit with support frame



Back Flush Kit

When used with Matala Filter Kits, Atlantic's professional Back Flush Kit virtually eliminates FilterFall maintenance. Add a Back Flush Kit to any Pro Series FilterFalls for fast, convenient, powered backwashing to save you time, trouble and a whole lot of mess.



MODEL : **Model: BFK100**
Description: Back Flush Kit for Pro Series FilterFalls

FilterFalls Accessories



Matala Filter Kits

Customize your FilterFalls with three-stage Matala Filter Kits. Coarse, medium and fine Matala filter mats reduce channeling, increase surface area and are back flushed more effectively than standard filter mats.

MODELS :

Model: MA1600
Description: BF1600 Matala Filter Kit

Model: MA1900
Description: BF1900 Matala Filter Kit

Model: MA2600
Description: BF2600 Matala Filter Kit



Model: MA3800
Description: BF3800 Matala Filter Kit

Bio-Balls

Atlantic's BB1500 contains 150 extremely durable, lightweight Bio-Balls that are easy to clean and reduce channeling. Each ball is 1½" in diameter and has nearly 25 square inches of surface area for bacterial colonization.

MODEL : **Model: BB1500**
Description: Bio-Balls 150 pcs.



Media & Bags

Atlantic's Media Bags are made with triple-stitched, heavy-duty netting and have a convenient drawstring to secure the media within your FilterFalls. Whether using lightweight media blocks, Bio-Balls, or heavy lava rocks, Atlantic's Media Bags are meant to last.



MODELS :

Model: BG2234
Description: 18" x 22" Media Bag

Model: BB1000
Description: 1 cubic ft. Bio-Tech Media Blocks with bag

Maintenance Products

Installing a beautiful water garden is only the beginning. Atlantic offers a full line of maintenance products that will keep your water feature healthy and beautiful for years to come. Our Biocuda treatments keep your pond crystal clear, while seasonal products like our Pond & Garden Protectors protect your water feature when the weather is less favorable. Whatever your maintenance needs, Atlantic has you covered!

Triton™ Ionizer

Atlantic is once again pleased to introduce an ALL NEW Triton Ionizer to the Water Garden industry. Atlantic's all new modular design is at the cutting edge of innovation, with tool-less, seamless integration with our award-winning Triton Check Valve! Safe for animals and plants and unaffected by sunlight and heat, this mineralized water maintains a residual ability to treat organics, greatly reducing the need for chemical treatments.



TRION2 Ionizer, TR215CV Check Valve and P53900 shown

Triton Ionizer Features:

- Safe for fish and plants
- Low maintenance
- Clears water without the use of harsh chemicals
- Level of mineralization is controlled by the LED panel
- Treats ponds up to 25,000 gallons
- Easily installed in any new or existing water feature
- Electrodes are easily replaced without tools
- 1-year warranty



NEW!

Model: **TRION2**
 Description: Electronic Water Clarifier
 Application: Pond / Pond-free / Fountain
 Input Voltage: 12 volt AC
 Watts: 2
 Inlet/ Outlet: 2" Sch40 PVC
 Includes: Outdoor transformer and copper test strips



Alkalinity / PH / Copper Test Strips

Part No: **TRION-TS**



Triton Ionizer Replacement Anode

Part No: **TRION2-RA**

How It Works:

The new Triton Ionizer utilizes the same union fittings and adapters as the Triton Check Valve, so connecting the Ionizer above or below the Check Valve takes only seconds. Periodic replacement of electrodes is just as simple. Instead of a whole assembly, only the electrodes are changed, again without needing tools. It doesn't get any simpler or better designed than this!



MAINTENANCE



Pond Treatments

Clarity-Blast+ The Ultimate Pond Cleaner

Clarity Blast+ breaks down organic debris with a powerful combination of bacteria, enzymes and a proprietary secret ingredient to clean waterfalls, streams, plant pots and filtration systems. With a patented process that combines bacterial cultures with natural extracts, Clarity Blast+ with Activated Barley helps to remove and control the pond hobbyist's worst long term pond problem.



Part #	Size	Gal. Treated	Part #	Size	Gal. Treated
5CB3/4	¾ lbs.	6,000 gal	5CB7	7 lbs.	56,000 gal
5CB21/2	2½ lbs.	20,000 gal			

- Removes Pond Owner's Worst Problem
- Removes Slimy Debris From Ponds, Waterfalls and Streams
- Safe for Aquatic and Domestic Animals



Eco-Klean Oxy Pond Cleaner

Eco-Klean quickly and safely removes attached organics from rocks, waterfalls, streambeds and anywhere else build-up occurs. Fast dissolving granules add oxygen to the pond, remove odors and, when used regularly, can actually eliminate the need for disruptive, expensive complete pond cleanouts.

- Immediately removes organic debris
- Deep cleans rocks, waterfalls, and streambeds
- Safe for Aquatic & Domestic Animals

Part #	Size	Gal. Treated	Part #	Size	Gal. Treated
5EK3/4	¾ lbs.	7,500 gal	5EK10	10 lbs.	100,000 gal
5EK21/2	2½ lbs.	25,000 gal			

Eco-Solv9 Complete Pond Cleaner

Eco-Solv9 is the fastest water clarifier on the market for all water features – pond, pond-free, fountain or bubbler. A full 9% of active ingredient, double that of competing brands, clears pond water regardless of color, gives better results and lasts far longer.



Part #	Size	Gal. Treated	Part #	Size	Gal. Treated
5ES16	16 oz.	9,600 gal	5ES64	64 oz.	38,400 gal
5ES32	32 oz.	19,200 gal	5ES1G	1 gal	76,800 gal

- Clears Water, regardless of color
- Removes attached and suspended organic debris
- 2X more concentrated

Quick-Clear Pond Flocculent

Quick-Clear rapidly restores brilliant clarity to cloudy or dirty pond water by causing suspended particles in the water to clump, or flocculate. The heavier clumps drop out of suspension to the bottom where they are easily filtered or vacuumed out, clearing the pond quickly and effectively.



Part #	Size	Gal. Treated	Part #	Size	Gal. Treated
5QC16	16 oz.	8,000 gal	5QC32	32 oz.	16,000 gal

- Clears Pond Water Fast
- Makes Pond Water Sparkle
- Safe for Aquatic and Domestic Animals



Re-Vive Dechlorinator Liquid

Re-Vive quickly removes chlorine, chloramines and heavy metals often present in municipal water supplies, while enhancing the protective slime coat that helps fish recover from wounds and abrasions. Re-Vive is especially beneficial in times of stress, protecting fish during top-offs, water changes and pond cleanouts.

- Immediately Removes Chlorine, Chloramine & Heavy Metals
- Adds Fish Slime Coat Protectant
- Safe for Aquatic & Domestic Animals

Part #	Size	Gal. Treated	Part #	Size	Gal. Treated
5RV16	16 oz.	3,200 gal	5RV32	32 oz.	6,400 gal

Bio-Max+ All Season Beneficial Bacteria

Bio-Max+ All Season liquid formulation removes ammonia and nitrites, as well as nitrates and organic debris, year 'round, in any water feature. The concentrated denitrifying bacteria and powerful enzymes in Bio-Max+ All Season Beneficial Bacteria rank it among the strongest on the market today.



Part #	Size	Gal. Treated	Part #	Size	Gal. Treated
5BM+16	16 oz.	48,000 gal	5BM+64	64 oz.	192,000 gal
5BM+32	32 oz.	96,000 gal	5BM+1G	1gal	384,000 gal

- Clears Water, Removes Debris and Seeds Filters
- Keeps Your Water Clear Year Round
- Safe for Aquatic and Domestic Animals



Bio-Max Beneficial Bacteria

To remove sludge, leaves, debris and odors, Bio-Max dry formula contains several billion bacteria per gram and 6 added enzymes. Potent bacterial strains, grown on Activated Barley in a patented process, clean and clear ponds, improve dissolved oxygen and lower nitrate levels that might otherwise feed rampant algae growth. Use along with Bio-Max+ in a weekly maintenance program to keep sludge at bay and water quality at its peak.

- Removes Sludge and Odor Fast
- Breaks Down Dead Algae, Leaves and Debris
- Safe for Aquatic and Domestic Animals

Part #	Size	Gal. Treated	Part #	Size	Gal. Treated
5BM1/3	⅓ lbs.	5,300 gal	5BM6	6 lbs.	96,000 gal
5BM1	1 lb.	16,000 gal			



Summer Fish Food

Biocuda Summer Food is formulated for warm weather feeding to produce maximum fish growth and color enhancement. The result of years of laboratory and extensive field research and development with top breeders, Biocuda Summer Food offers a premium blend of vitamins and minerals specifically designed to aid in color, growth and vitality of your fish.

Water Temperatures 65°F and above

- Nitrogen flushed for maximum freshness
- Never clouds water
- Contains natural pigments for maximum color enhancement

Part #	Size
BCS050	½ lb.
BCS125	1¼ lbs.
BCS500	5 lbs.



Cold Water Fish Food

Biocuda Cold Water Food is designed for cool weather feeding and color enhancement of your fish. It is formulated for high palatability and digestibility to minimize excreted waste. Biocuda Cold Water Food contains stable Vitamin C and Brewer's Yeast to promote fin, gill and tissue development, while nutrient supplements aid in overall fish health and resistance to disease.

Water Temperatures 55°F to 65°F

- Contains wheat germ to aid in digestion
- Never clouds water
- New supplements to improve overall health and disease resistance

Part #	Size
BCC050	½ lb.
BCC125	1¼ lbs.
BCC500	5 lbs.



Atlantic's Typhoon Air Pumps feature indoor/outdoor, continuous duty diaphragm compressors specifically designed for year-round usage. Ideal for aeration and circulation in warm weather, these aerators are especially dependable for de-icing and gas exchange in freezing weather, unlike floating de-icers that often fail under harsh conditions. Best of all, energy-efficient Typhoon Air Pumps draw only a tiny fraction of the power, and can easily be rebuilt for exceptionally long life!

NEW!

Typhoon

AIR PUMPS



Shallow aeration keeps ice from forming all winter long.

MODELS :



Model: TA1800
Description: Diaphragm Air Pump
Outlet : ⅜" insert, ½" slip
Volts: 115
Watts: 25
Max Pressure: 3 PSI
Max Depth: 7'
Cord Length: 6'



Model: TA3600
Description: Diaphragm Air Pump
Outlet : ⅜" insert, ⅝" slip
Volts: 115
Watts: 35
Max Pressure: 5 PSI
Max Depth: 11'
Cord Length: 6'

Typhoon Air Pumps Feature:

- Weather-proof aluminum housing
- Noise dampening design
- Energy efficient & low maintenance
- 1-year warranty

Model #	Output (LPM)					
	Max	@2'	@4'	@6'	@8'	@10'
TA1800	30	21	13	4		
TA3600	60	47	34	23	12	3



Model: TAKIT1800
Description: TA1800 Aeration Kit
Includes: TA1800, 25' air line, in-line check valve and 6" airstone



Model: TAKIT3600
Description: TA3600 Aeration Kit
Includes: TA3600, 35' air line, (2) in-line check valves, 2-way splitter, and (2) 6" airstones

Typhoon Aeration Kits **NEW!**

Year-round pond aeration has never been easier than with Atlantic's NEW Typhoon Aeration Kits. These Kits provide complete solutions to your pond's aeration needs, winter and summer. Whether you need deep warm weather circulation, or shallow winter de-icing, these Kits come with everything you need, including premium airline tubing, long-lasting airstones, inline check valves and all the fittings.

Pond & Garden Protector

Want a healthy pond first thing in the Spring? Protecting your pond in the fall is the best way to get a head start. To ensure a healthy winter environment for fish and to reduce spring maintenance, simply keep leaves and windblown debris from entering the pond in the fall. When a traditional pond net becomes laden with leaves that lay on or under the water surface, the leaves begin to decompose, affecting water quality and adding unwanted nutrients to the ecosystem. The domed design of Atlantic's Pond & Garden Protectors causes leaves to roll off the net where they can be collected easily. Easy to assemble and remove, the Pond & Garden Protector is the best and easiest way to start the new year off with a clean, healthy pond.

Includes:

- Ultra Pond Net
- Nylon Base
- Center Receptor
- (4) Fiberglass Poles
- (4) 12' Tie-downs
- (4) Ground Stakes
- (12) Net Stakes
- (8) Net Clips



Kit No.	Size	Net
PGPSM	7' x 9'	15' x 20'
PGPLG	9' x 12'	20' x 20'



POND FEATURES:

- Keeps out leaves and other windblown debris
- Protects fish from heron and other predators
- Helps prevent algae growth by reducing organic waste



GARDEN FEATURES:

- Protects fruiting plants and vegetables
- Allows for sunlight and optimum plant ventilation
- Can be covered with plastic to protect against frost



Ultra Pond Nets

Constructed of heavy-duty UV-resistant polypropylene, Ultra Pond Nets will last for years. The 1/2" x 1/2" opening keeps debris out while allowing sunlight and fresh air to enter. Includes 12 plastic stakes.

Ultra Pond Nets Include:

- Heavy-duty pond netting
- 1/2" x 1/2" hole size
- UV-resistant
- Each net is packed with 12 net stakes



MODELS:

Part No: **PN1015**

Size: 10' x 15'

Part No: **PN2020**

Size: 20' x 20'

Part No: **PN1520**

Size: 15' x 20'

Part No: **PN2030**

Size: 20' x 30'

MAINTENANCE

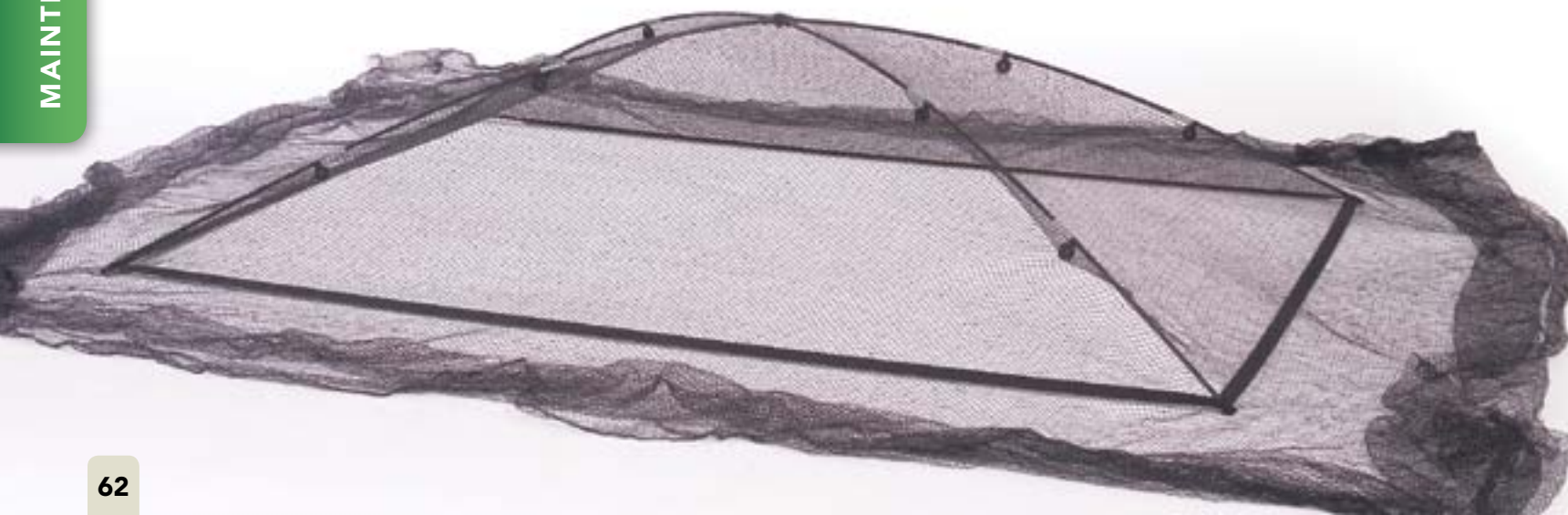

MAINTENANCE

Rain Harvesting Products

Whether using a small rain barrel or a large in-ground reservoir, Atlantic's innovative Rain Harvesting components are right for your project. With products like our Clean Rain Ultra Downspout Diverter, Eco-Blox and specially designed Rain Harvesting Pump Vault, we have everything you need to capture, store and re-use rain and storm water, allowing you to help the planet by reducing runoff while saving money on your water bill. Above ground, under pavers or below a waterfall, we have your Rain Harvesting solution.



Clean Rain Ultra Downspout Diverter

Atlantic's all-in-one rainwater filtration and collection system collects, cleans and filters rainwater and accommodates multiple connection methods for immediate or future use in the garden and around the yard. User-friendly construction makes the Downspout Diverter a breeze to install and just as easy to use, the perfect 'green' product for anyone looking to conserve and re-use rainwater.

Clean Rain Downspout Diverter Features:

- Collects water from downspouts
- Leaf Eater rain head deflects leaves and debris
- Downspout Diverter automatically flushes away contaminants in the initial surge of runoff
- Includes stainless steel mosquito-proof screen
- Easy to install
- Can be mounted at any height for easy maintenance
- Works automatically once installed
- Can be switched off in winter months
- Connects to majority of hose sizes



Model: RHCRU
Dimensions: 8¼" L x 9" W x 31" H
Inlet / Outlet: 2" x 3" and 3" x 4" downspout - 3" and 4" Sch 40
Diverter Outlet: Garden hose, flex pipe and 3" Sch 40



Hydro Activated Filtration™ technology uses the rainwater's force to deflect leaves and debris off the screen.



Automatically works for every rainfall event.

The cover and cap provide a stylish, integrated finish and in colder climates, avert snow.

An easily accessible on/off switch to direct your rainwater for collection or return to normal downspout functioning.

Specially designed overflow mechanism ensures excess water safely overflows down your downspout.

Smart Sense™ First Flush functionality ensures that the majority of contaminants from the roof are flushed down the downspout.



Smart Sense's self regulating valve automatically adjusts to divert the optimum amount of dirty rainwater based on the intensity of the rainfall event.

The hose outlet fits standard garden, pool and sump hoses and the cap removes to fit 3" Schedule 40 pipe.

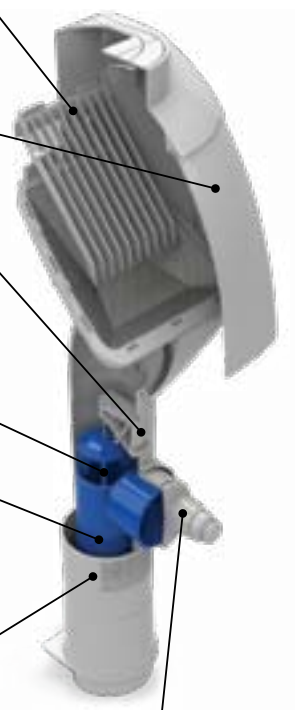

Downspout Adaptors Included

Fits 2" x 3", 3" x 4" and 3", 4" downspouts



2" x 3" & 3" x 4"



3" and 4" round Sch 40 pipe

Compatible Hoses

Also fits 3" Schedule 40 pipe

Garden Hose



Standard

Sump Hose



1"

Pool Hose



1½"

Rain Harvesting Products

Atlantic's innovative Rain Harvesting components give you the ability to choose the best way to collect clean rainwater for future use. Using a combination of our Clean Rain Ultra, Rain Harvesting Pump Vault and Eco-Blox, our versatile products allow you to collect rainwater in a traditional cistern, below permeable pavers or in pond-free applications to give you the best system to fit your needs.

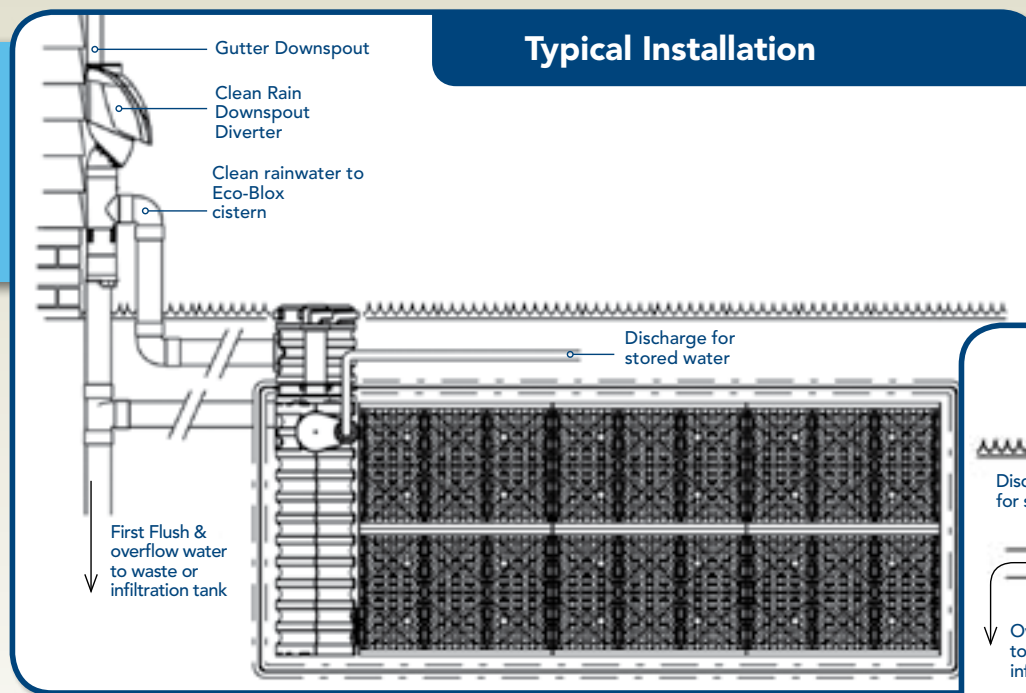

Typical Installation

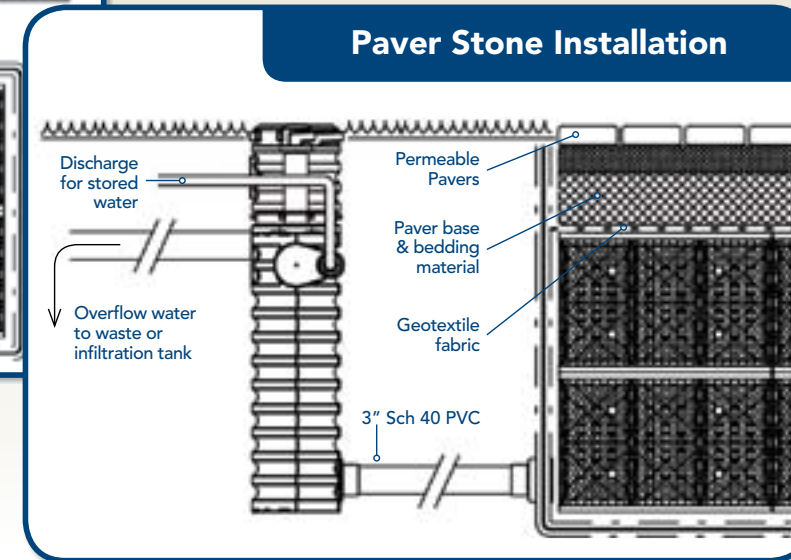

Paver Stone Installation

How It Works:

Rainwater is collected from the gutter downspout and flows into the Clean Rain Ultra Downspout Diverter, which cleans waste, dirt and debris from the water. After the first flush of water is sent to waste, clean water then flows to the Eco-Blox reservoir to be stored for future use.

MODEL :

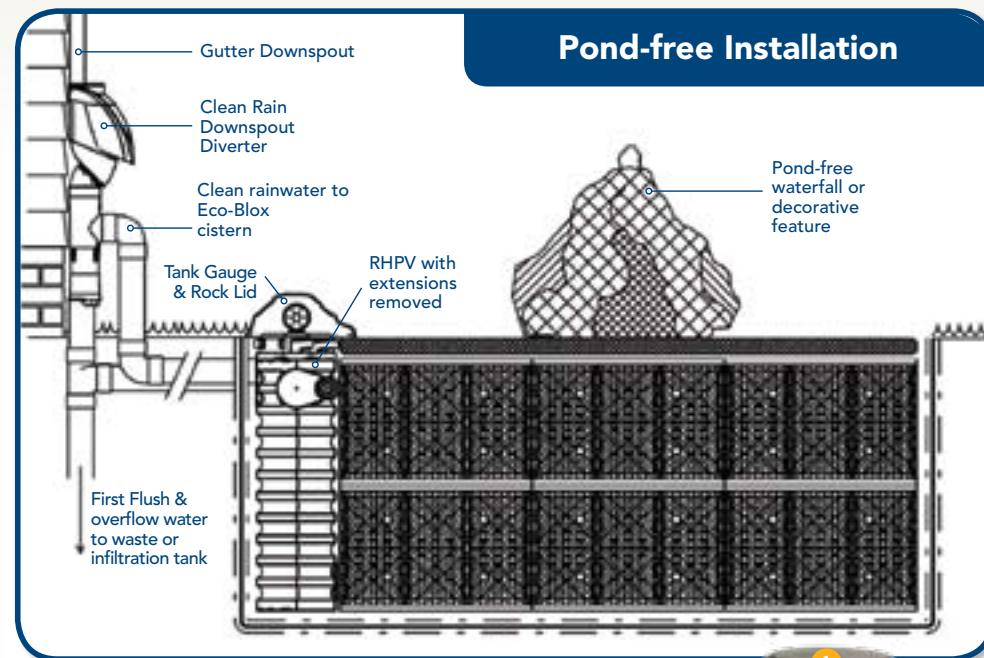

Pond-free Installation

Pump Performance:

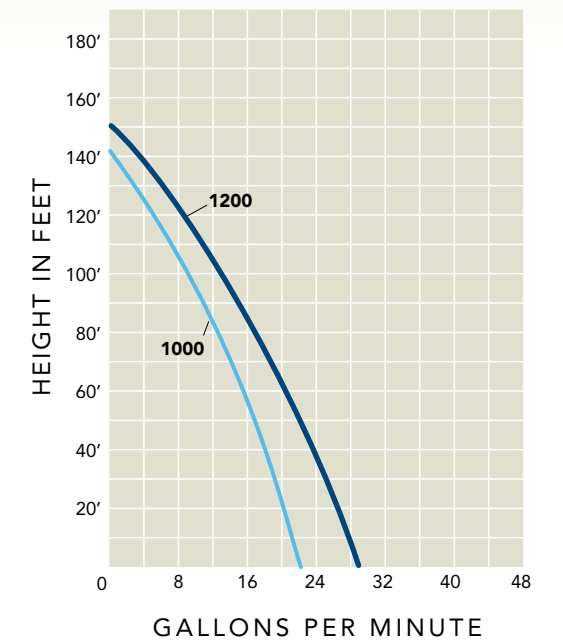

MODELS :



Model: RHEB510
Description: External Pressure Pump
Dimensions: 18"L x 11"W x 13"H
Cord Length: 5'
Volts: 115 **Max Flow:** 22 gpm
Watts: 1000 **Max Pressure:** 64 psi

- Incredibly quiet, self-priming, water-cooled pump
- Built-in pressure switch & flow sensor
- Equipped with run-dry protection and internal check valve
- Automatically starts and stops when taps are opened
- Delivers constant pressure & flow rates



Model: RHDIV12
Description: Submersible Pressure Pump
Dimensions: 6"L x 6"W x 19"H
Cord Length: 48'
Volts: 115 **Max Flow:** 29 gpm
Watts: 1100 **Max Pressure:** 65 psi

- Extremely reliable and easy to install
- Built-in pressure switch & flow sensor
- Equipped with run-dry protection and internal check valve
- Automatically starts and stops when taps are opened
- Delivers constant pressure and flow rates

Rain Harvesting Pump Vault Features:

1. Twist lock lids allow safe, easy access to the pump chamber and 3" tank gauge riser (gauge optional)
2. Comes with a 1" FIPT Spinweld® fitting for a pressure pump discharge and flat panels for additional plumbing
3. (2) 3" FIPT inlets allow installation inside the liner or out, via 3" lines and bulkhead fittings to remote Eco-Blox cistern
4. Risers allow for 13" of backfill and can be removed for pond-free installations
5. Equipped with flat panels for installing additional pump lines, downspout diverters and overflows

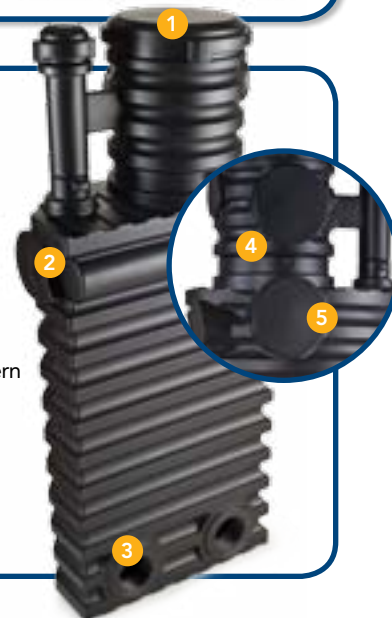

Model: RHPV
Description: Pump Vault
Dimensions: 20"L x 11"W x 48"H
Inlet: (2) 3" FIPT openings
Opening: 9½"
Outlet: 1" spinweld
Max Pump Flow:

- Inside the Liner: 7,500 gph
- External @ 10' 6,500 gph
- External @ 20' 5,000 gph
- External @ 30' 2,000 gph



Clean Rain Ultra
 For features & specs See page 65.

Pro Series Eco-Blox
 For features & specs See page 27.

Rain Harvesting Products

Leaf Eater

Attach a Leaf Eater to your downspout to ensure that no debris enters your basin. Easy to install, with a stainless steel mosquito-proof screen and pivoting outlet for either rear or bottom discharge, the Leaf Eater is both simple and effective.



Model: RHLE
Description: Leaf Eater
Dimensions: 7½"L x 6½"W x 9½"H
Outlet: 3" Sch 40

- Compact, versatile rain head is easy to install
- Prevents debris from entering the basin
- Outlet pivots for rear or bottom discharge
- Includes stainless steel mosquito-proof screen

Tank Gauge

Atlantic's Tank Gauge allows you to easily monitor the water level in your basin, and installs easily into any Atlantic Pump Vault.



Model: RHTG
Description: Tank Gauge
Dimensions: 3¾"L x 2¾"W x 4½"H
Outlet: Requires 1¼" hole for installation

- Monitors water level of any storage system
- Quick and easy to install, suitable for all new and existing tanks
- Easy to read dial face with empty and full indicators
- Can be calibrated for holding systems up to 8' deep

Collapsible Rain Barrel

Our Rain Barrel connects easily to our Downspout Diverter and can be disassembled in minutes for easy storage when not in use. Garden hose fittings make it easy to deliver stored water wherever it's needed.

Model: RHCRB
Description: Collapsible Rain Barrel
Dimensions: 24"W x 36"H
Outlet: Spigot & garden hose

- Easy assembly connects to the downspout diverter
- Constructed of flexible wear resistant PVC with sturdy aluminum frame
- Collapsible and easy to store when not in use
 - 60 gallon capacity



Rain Harvesting Kits

Atlantic's Rain Harvesting Kits provide you with everything you need to harvest rainwater. From the Clean Rain Ultra Downspout Diverter to your Eco-Blox basin and a pump to retrieve your water, we've got you covered. Available in 500 and 1000 gallon sizes, these Kits are a great way to conserve rainwater for future use, cut down on your monthly water bill and, in some locales, even qualify for tax credits!



RainHarvesting Kit with RHDIV12 Submersible Pressure Pump:

- Clean Rain Ultra Downspout Diverter
- Rain Harvesting Pump Vault
- 45 mil EPDM pond liner
- Heavy-duty underlayment
- RHDIV12 Submersible Pressure Pump
- Tank Gauge
- Eco-Blox
- Fittings

Kit No.	Capacity	Liner Size	Underlayment	Eco-Blox
RHKIT500DIV	504 gal	15' x 20'	(2) 12' x 25'	16
RHKIT1000DIV	945 gal	20' x 25'	(4) 12' x 25'	32



RainHarvesting Kit with RHEBS10 External Pressure Pump:

- Clean Rain Ultra Downspout Diverter
- Rain Harvesting Pump Vault
- 45 mil EPDM pond liner
- Heavy-duty underlayment
- RHEBS10 External Pressure Pump
- Tank Gauge
- Eco-Blox
- Fittings

Kit No.	Capacity	Liner Size	Underlayment	Eco-Blox
RHKIT500EBS	504 gal	15' x 20'	(2) 12' x 25'	16
RHKIT1000EBS	945 gal	20' x 25'	(4) 12' x 25'	32

Atlantic CLASSIC

FASTFALLS MODELS:



Model: SP1400
 Dimensions: 16"W x 11"D x 9"H
 Waterfall Width: 14"
 Max Pump Flow: 2,000 gph
 Bulkhead: 1 1/2"
 Other: Includes retail packaging



Model: SP2500
 Dimensions: 27"W x 11"D x 10"H
 Waterfall Width: 25"
 Max Pump Flow: 4,000 gph
 Bulkhead: 2"
 Other: Includes retail packaging



Model: SP3600
 Dimensions: 38"W x 13"D x 9"H
 Waterfall Width: 36"
 Max Pump Flow: 6,000 gph
 Bulkhead: 2"
 Other: Includes retail packaging



Model: SP4800
 Dimensions: 50"W x 11"D x 10"H
 Waterfall Width: 48"
 Max Pump Flow: 8,000 gph
 Bulkhead: (2) 2"
 Other: Includes retail packaging



SKIMMER MODELS:



Model: PS4000
 Weir Width: 6"
 Dimensions: 17 1/2"W x 24"D x 22"H
 Pump Flow Range: 1,000 - 3,000 gph
 Sq. Ft. Rating: 300
 Filtering: Basket, Mat
 Match to FilterFalls: BF1000/BF1250
 Other: Includes retail packaging



Model: PS4500
 Weir Width: 9"
 Dimensions: 17 1/2"W x 24"D x 22"H
 Pump Flow Range: 2,000 - 4,000 gph
 Sq. Ft. Rating: 600
 Filtering: Basket, Mat
 Match to FilterFalls: BF1500
 Other: Includes retail packaging

COMBO KITS:



Combo Kit Model: **FILT27**
 Skimmer Model: PS4500
 FilterFalls Model: BF1250



Combo Kit Model: **FILT25**
 Skimmer Model: PS4000
 FilterFalls Model: BF1250



Combo Kit Model: **FILT23**
 Skimmer Model: PS4000
 FilterFalls Model: BF1000

CLASSIC

Atlantic Classic is where quality meets affordability. Aimed at the do-it-yourselfer, Atlantic's Classic Skimmers, FilterFalls and FastFalls are the perfect products with which to install and maintain a beautiful water feature. Find out why, year after year, Atlantic's Classic products have been among the most popular in the water garden industry.

ECHO-CHAMBER MODELS:



Model: ECT250
 Dimensions: 46"W x 29"D x 27"H
 Max Pump Flow: 10,000 gph
 Capacity: 100 gal
 Grate: Polyethylene w/heavy-duty support bars



Model: SEC250
 Dimensions: 46"W x 29"D x 27"H
 Max Pump Flow: 10,000 gph
 Capacity: 100 gal
 Grate: Galvanized steel

FILTERFALLS MODELS:



Model: BF1000
 Waterfall Width: 14" spillway
 Dimensions: 16"W x 20"D x 14"H
 Pump Flow Range: 1,500 - 2,500 gph
 Bulkhead: 1 1/2"
 Match to Skimmer: PS4000
 Includes: Retail packaging and top grate



Model: BF1250
 Waterfall Width: 17" spillway
 Dimension: 19"W x 22 1/2"D x 14"H
 Pump Flow Range: 2,000 - 3,000 gph
 Bulkhead: 1 1/2"
 Match to Skimmer: PS4500
 Includes: Retail packaging and top grate



Model: BF1500
 Waterfall Width: 20 1/2" spillway
 Dimensions: 24"W x 30"D x 20"H
 Pump Flow Range: 2,500 - 4,000 gph
 Bulkhead: 1 1/2"
 Match to Skimmer: PS4500
 Includes: Retail packaging *no top grate

Retail POP & Training Materials



Description: Colorfalls & Colorfalls Kit / Biocuda Water Treatment Guide / TidalWave Pumps Tri-fold
Dimensions: 3¼"W x 8½"H



Description: Let's Talk Ponds / Pond-free / Water Features Tri-fold
Dimensions: 8½"W x 11"H (11" x 25½" open)



Description: Atlantic Retractable Floor Banner
Dimensions: 33½"W x 78"H



Description: Atlantic Wall Banner / Colorfalls Wall Banner
Dimensions: 60"W x 36"H



Description: Colorfalls Retractable Floor Banner
Dimensions: 33½"W x 78"H



Description: TidalWave Counter Mat
Dimensions: 19"W x 14"H



Description: Atlantic Water Garden University
 Visit www.atlanticwatergardens.com for more details

